

BC BUILDING CODE INTERPRETATION COMMITTEE

A joint committee with members representing
AIBC, APEGBC, BOABC, POABC

File No: 06-0099

INTERPRETATION

Page 1 of 2

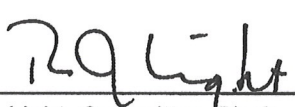
Interpretation Date:	October 18, 2011 (<i>revised April 17, 2012</i>)
Building Code Edition:	BC Building Code 2006
Subject:	Integrity of Exits, Building Service Penetrations
Keywords:	Exit, fire separation, service penetrations, electrical wires and cables
Building Code Reference(s):	3.1.9.1., 3.1.9.3. , 3.1.9.4. , 3.4.4.4.(1)(b)
Question:	<p>Can a wall that acts as a fire separation between an exit and the remainder of the building contain building service penetrations for electrical wires, cables, totally enclosed noncombustible raceways and noncombustible piping where such penetrations occur only on the remainder of the building side and where the building services do not serve the exit?</p>
Interpretation:	<p>Yes</p> <p>Sentence 3.4.4.4.(1) restricts the type of "openings" that are permitted through a fire separation that separates an exit from the remainder of the building.</p> <p>If a building service penetration does not fully penetrate from the building side to the exit side, it does not create an "opening" between the exit and the remainder of the building.</p> <p>Provided that such service penetrations, including electrical outlet boxes, are firestopped with a firestop system that has been tested to ULC-S115 as required by Article 3.1.9.1. they are permitted to penetrate the building side of the fire separation wall.</p> <p><i>The service penetrations must also comply with Articles 3.1.9.3. and 3.1.9.4.</i></p> <p><i>Refer to the attached drawing on Page 2</i></p> <p> _____ R. J. Light, Committee Chair</p>
<p>The views expressed are the consensus of the joint committee with members representing AIBC, APEGBC, BOABC, and POABC, which form the BC Building Code Interpretation Committee. The purpose of the committee is to encourage uniform province wide interpretation of the BC Building Code. These views should not be considered as the official interpretation of legislated requirements based on the BC Building Code, as final responsibility for an interpretation rests with the local Authority Having Jurisdiction. The views of the joint committee should not be construed as legal advice.</p>	
<p>1107875 / 2012-04-09</p>	

BC BUILDING CODE INTERPRETATION COMMITTEE
A joint committee with members representing
AIBC, APEGBC, BOABC, POABC

File No: 06-0099

INTERPRETATION

Page 2 of 2

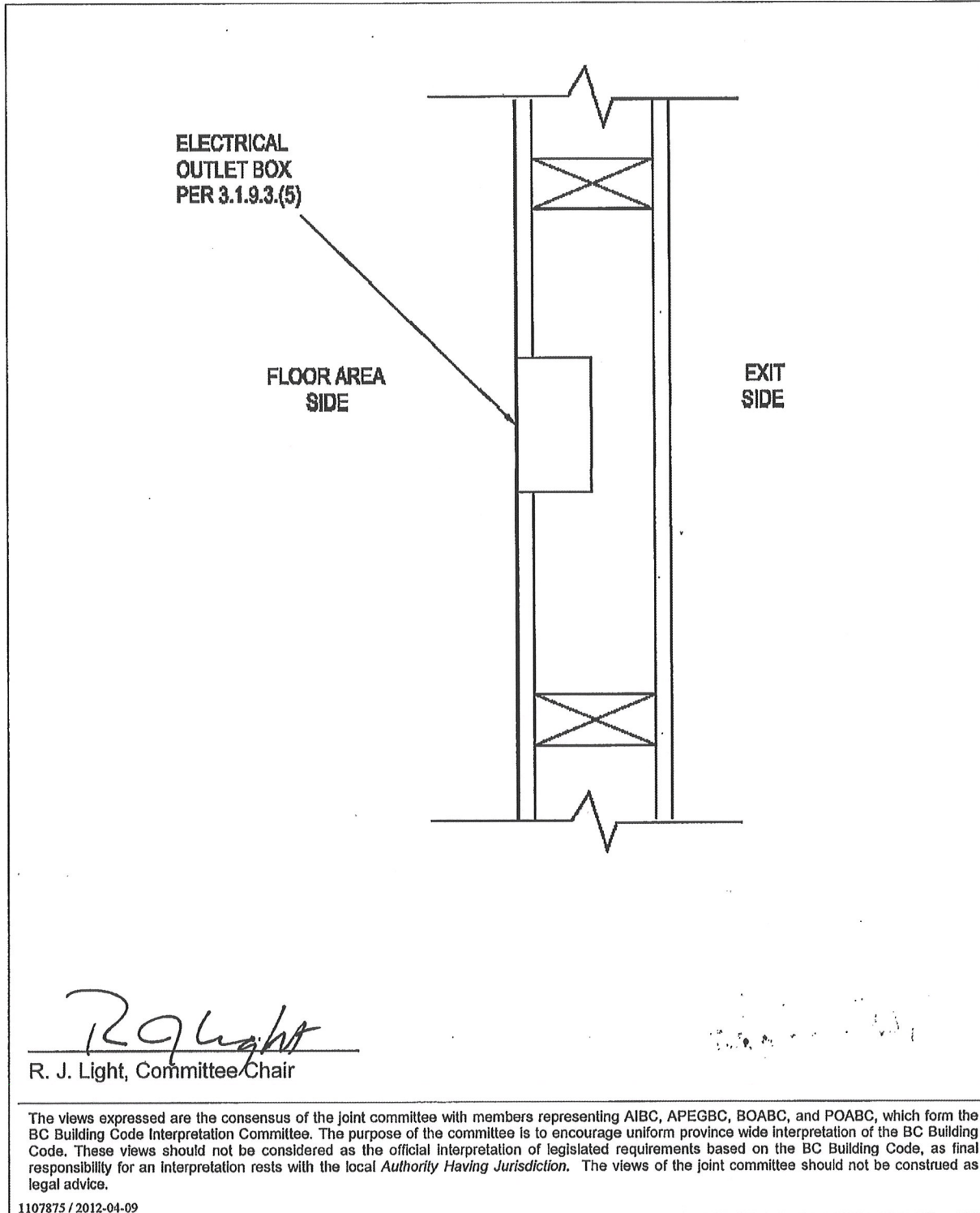

R. J. Light
R. J. Light, Committee Chair

The views expressed are the consensus of the joint committee with members representing AIBC, APEGBC, BOABC, and POABC, which form the BC Building Code Interpretation Committee. The purpose of the committee is to encourage uniform province wide interpretation of the BC Building Code. These views should not be considered as the official interpretation of legislated requirements based on the BC Building Code, as final responsibility for an interpretation rests with the local Authority Having Jurisdiction. The views of the joint committee should not be construed as legal advice.