



Why Presentation?

- Proper design / construction is important (for long-term durability)
- Buildings Inspectors responsibility / role
- Lack of information / misinformation

What is Air?

N₂ gas (78%)

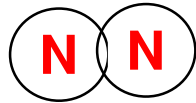

O₂ gas (21%)

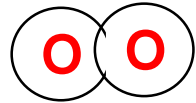

Argon gas (1%)



other gases < 1%
(CO₂, Ne, He, CH₄)

N₂ gas (< 78%)

O₂ gas (< 21%)

H₂O gas (0% - 3%)

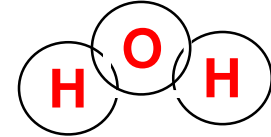

Argon gas (< 1%)

other gases (< 1%)
(CO₂, Ne, He, CH₄)

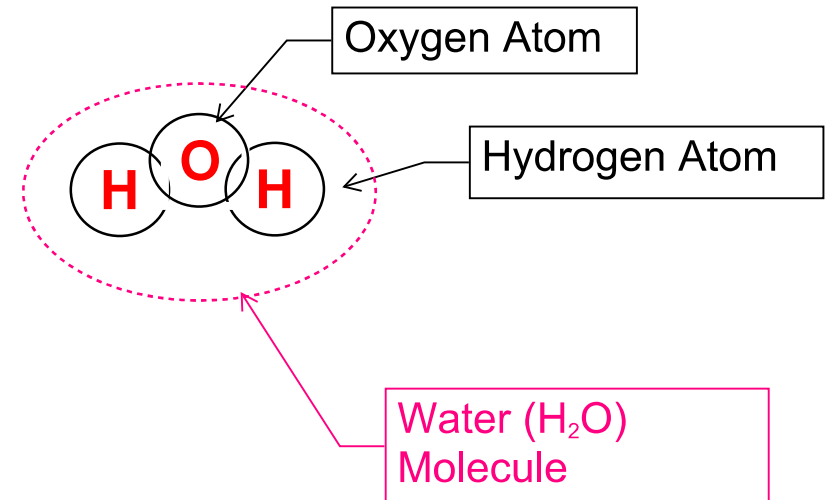
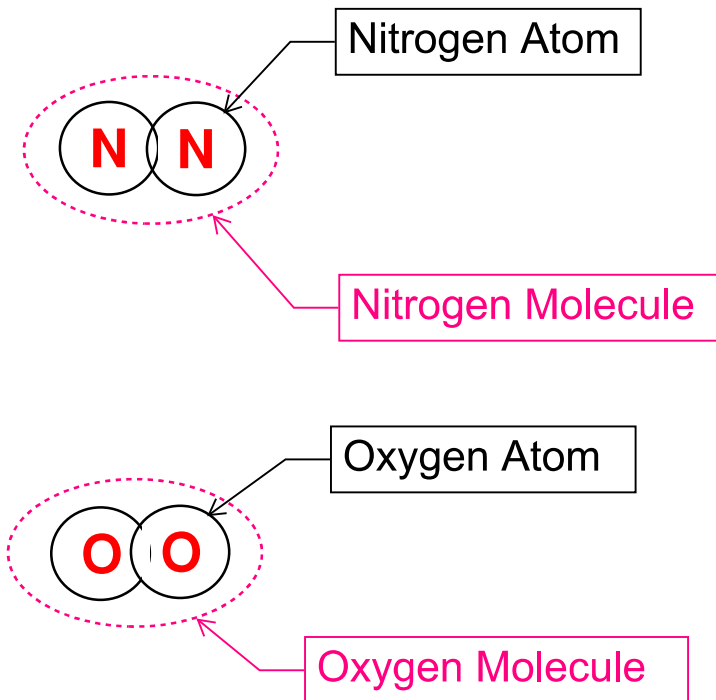

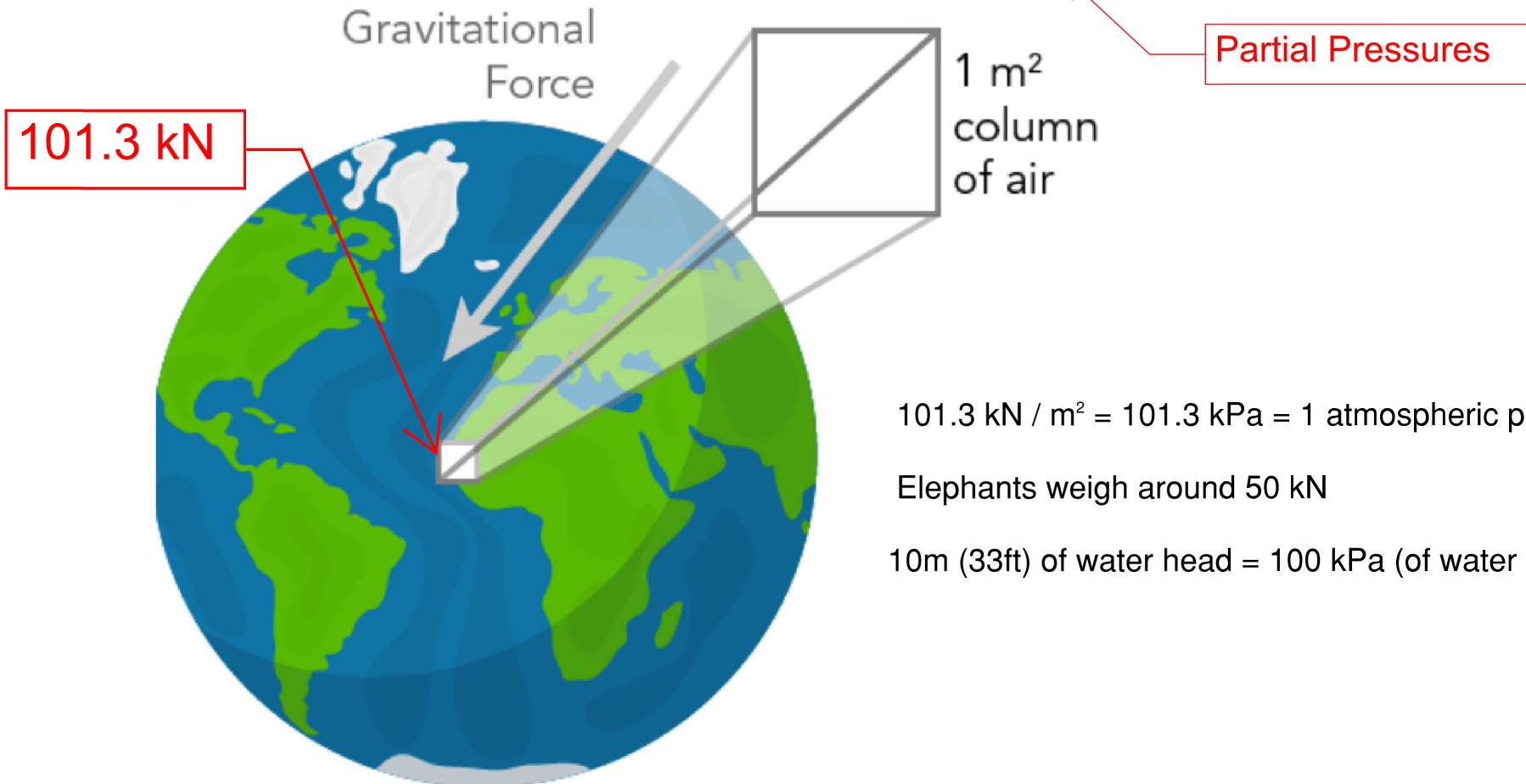
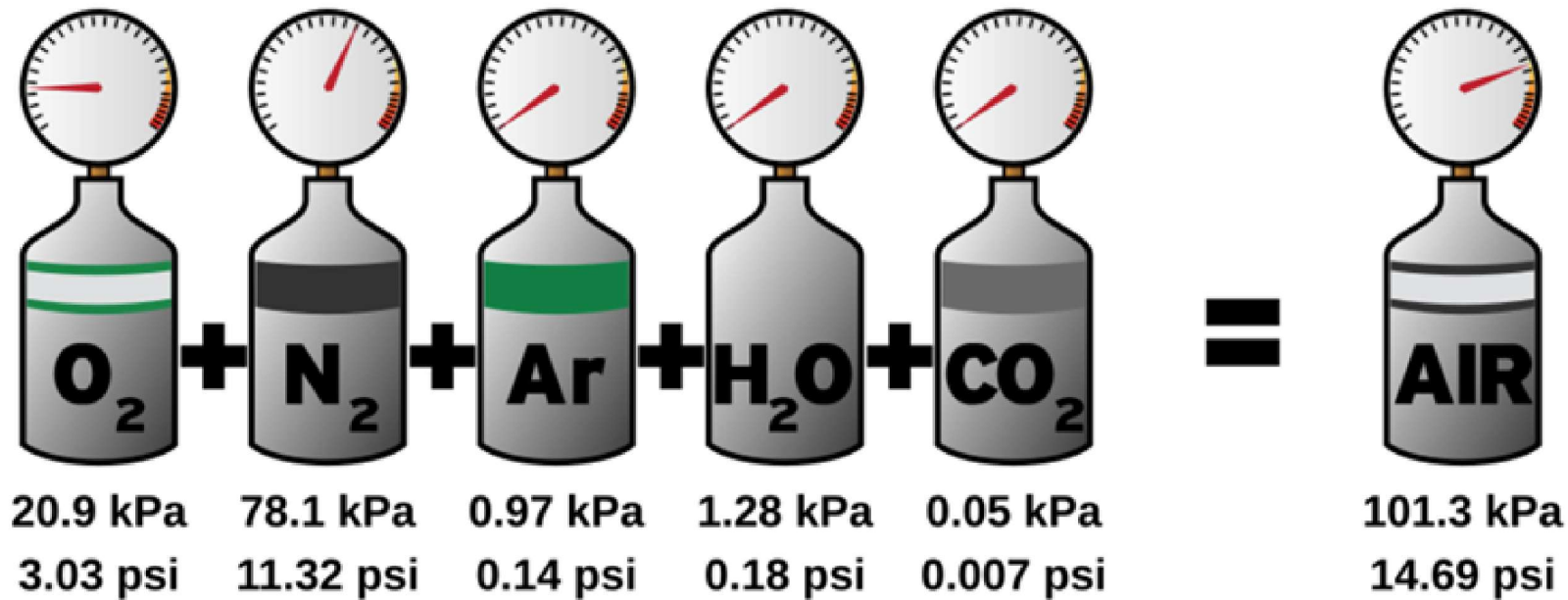

Atmospheric Pressure & Gravity Loads

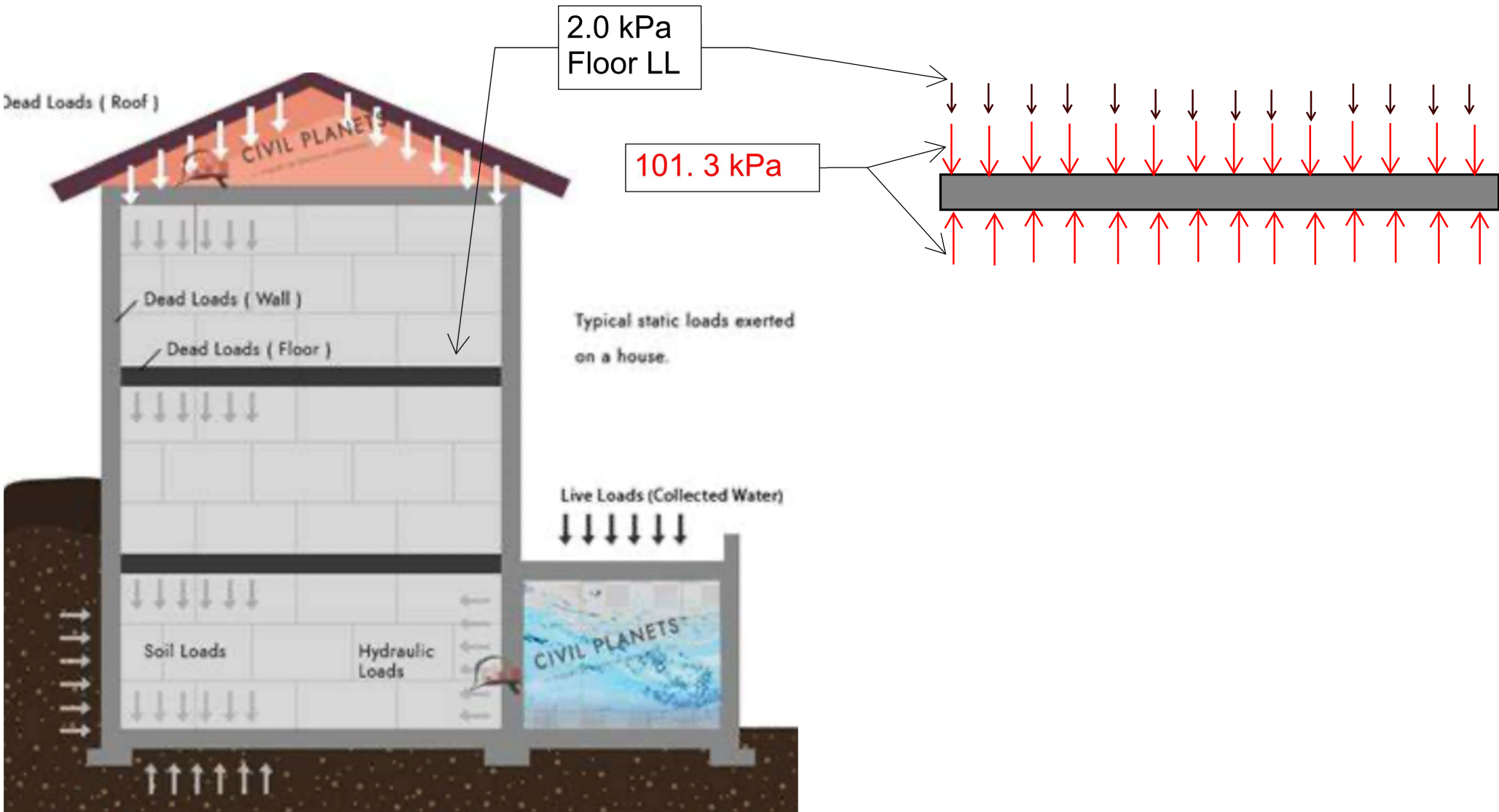

Uniqueness of Water Molecules

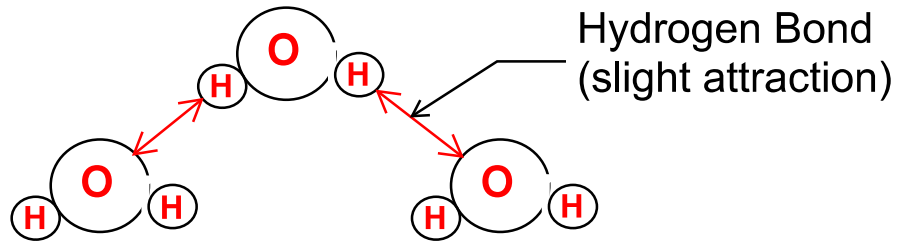
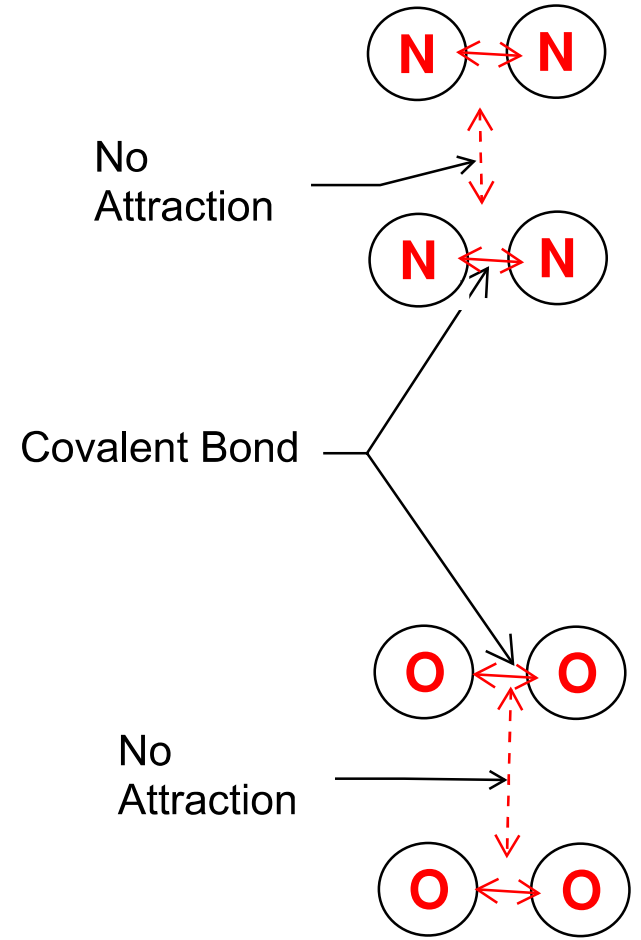
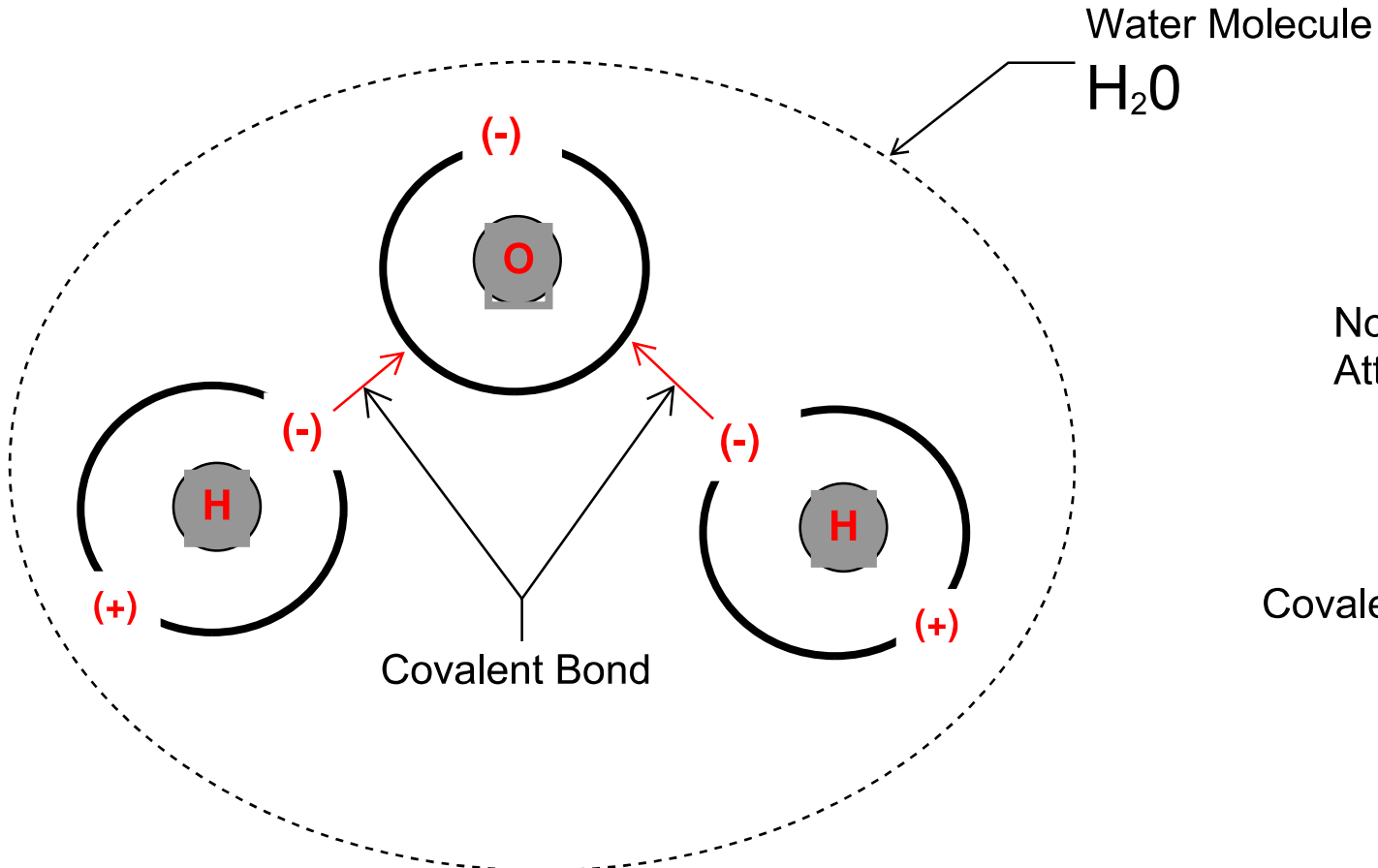

Smallness of Water Molecules

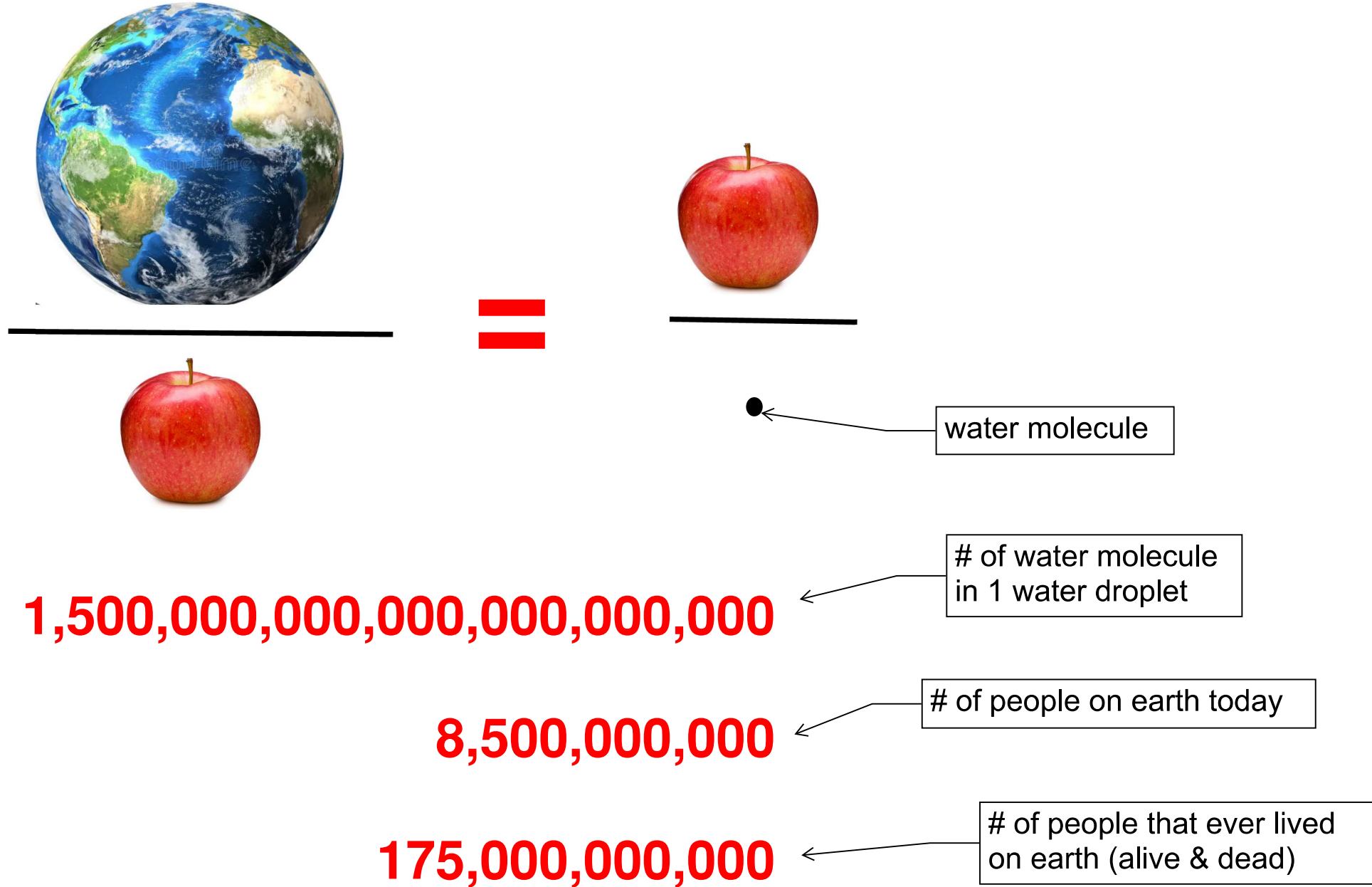

Temperature & Molecule Velocity

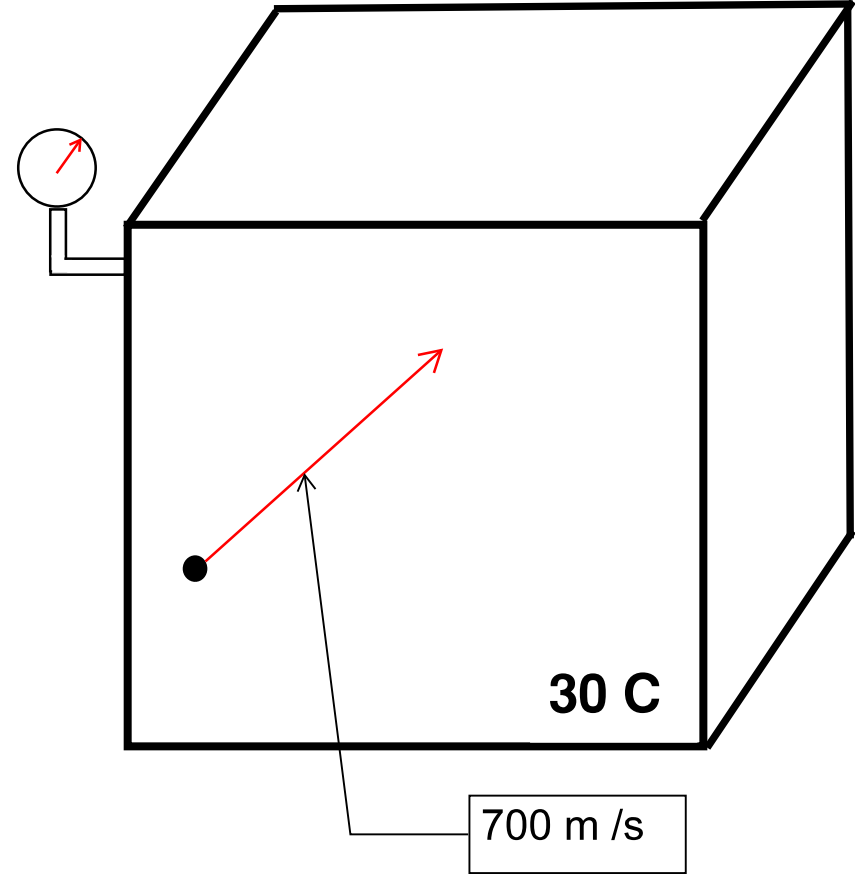
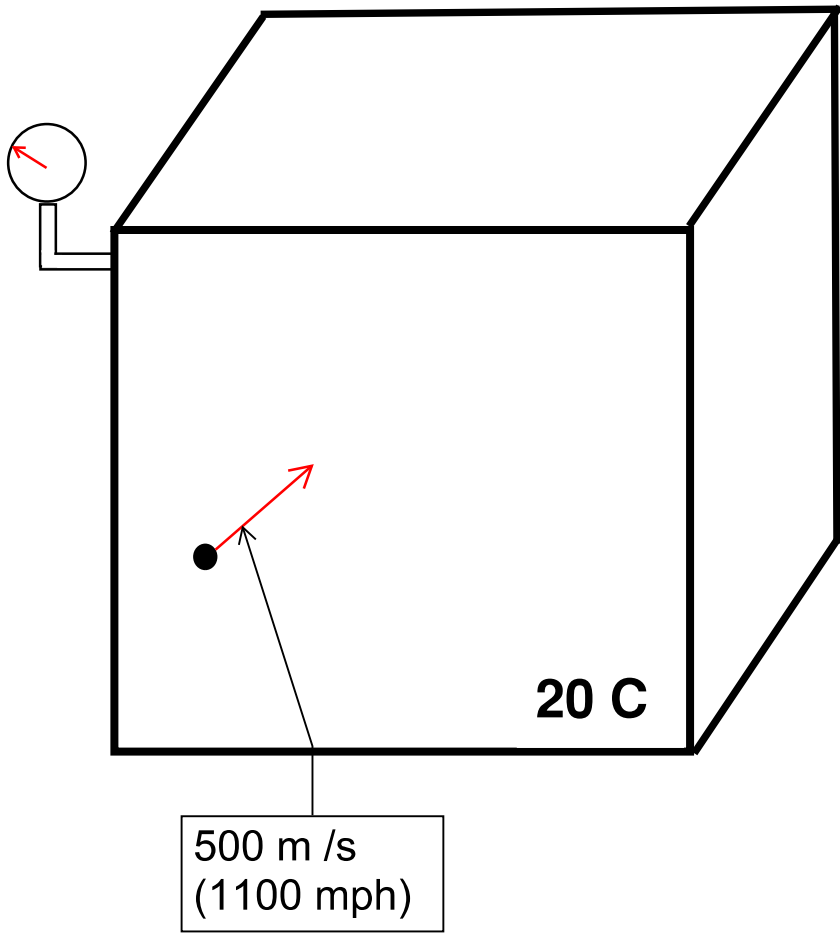

increase in temperature



molecules speed increases
increase in internal pressure

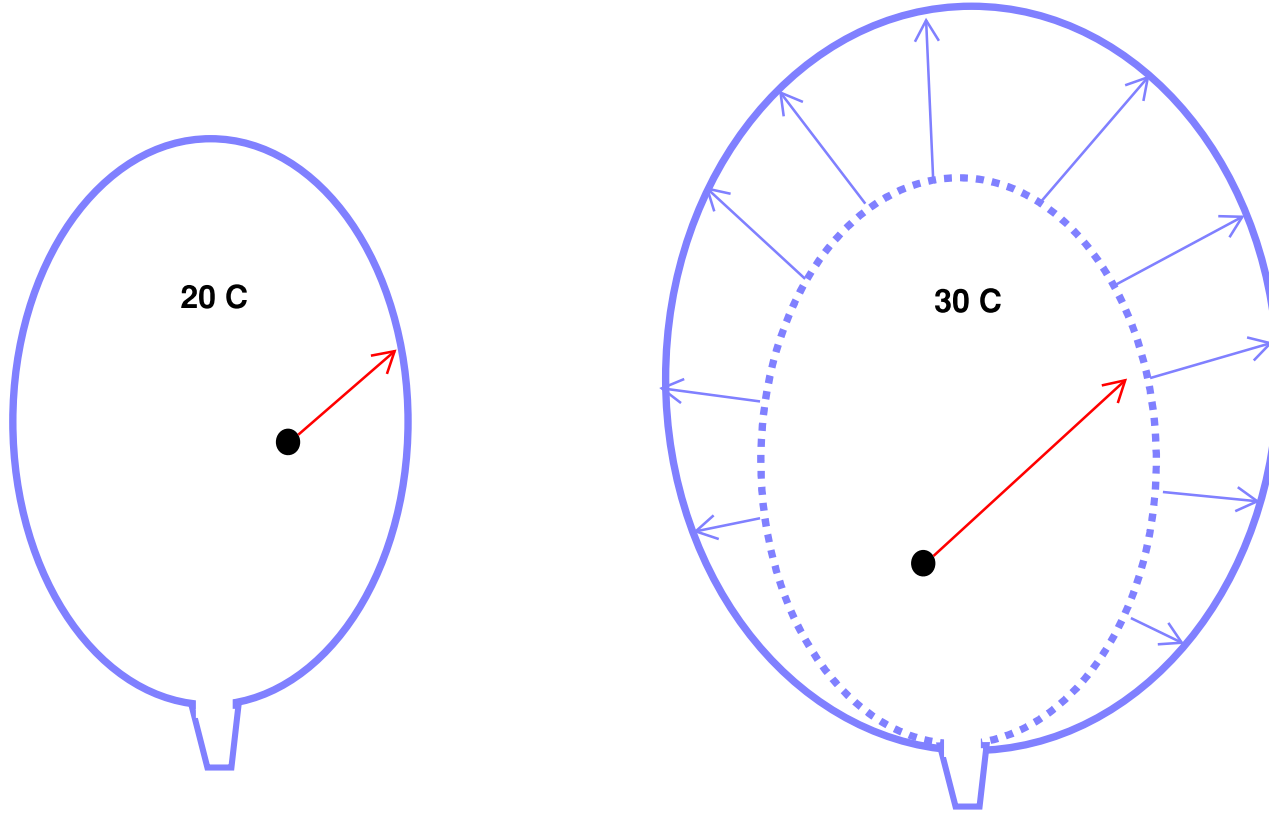

increase in temperature



molecules speed increases
increase in volume
no change on interior pressure

Temperature & Molecule Velocity & Molecular Collisions

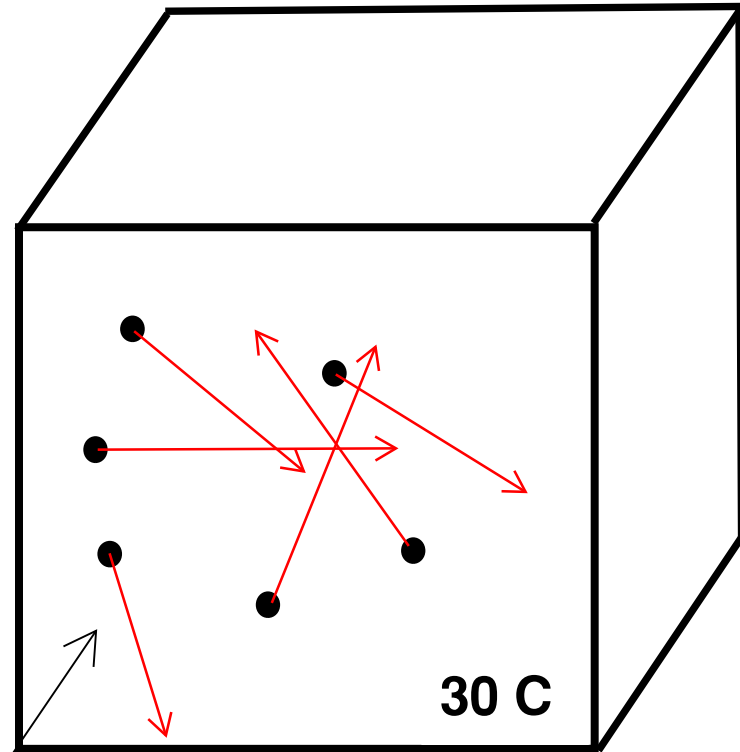
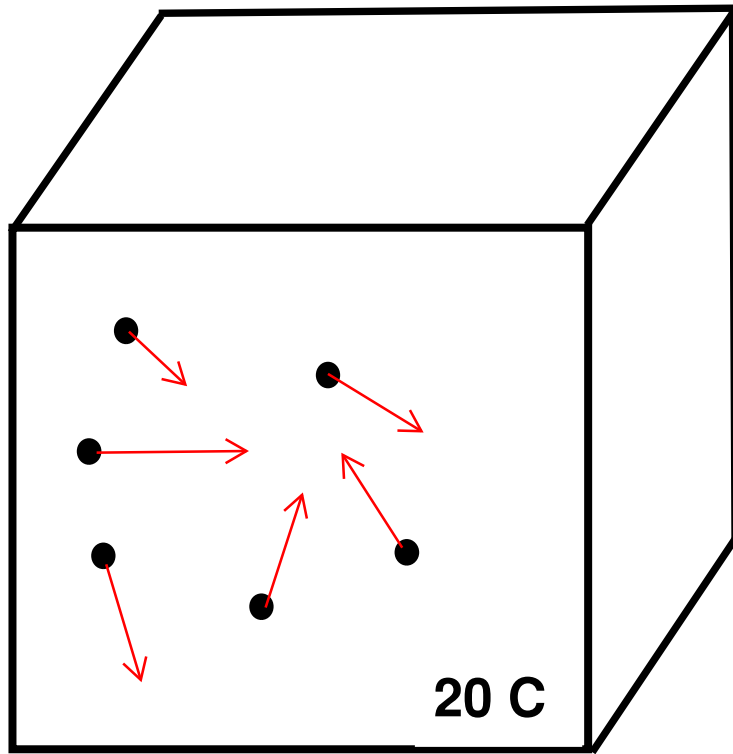

more inter-molecular collisions occurring
more force with collisions

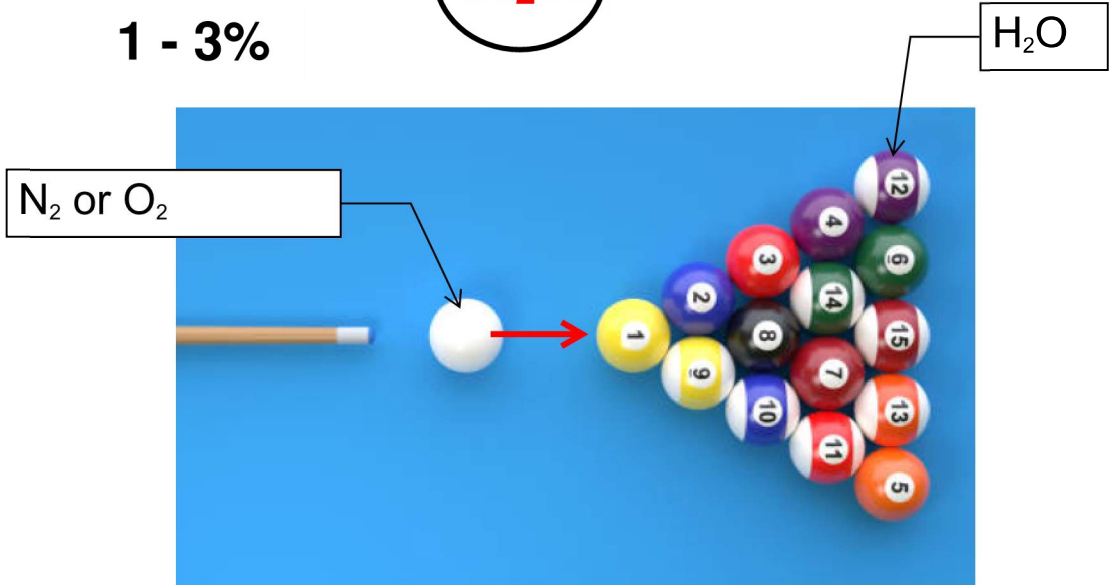
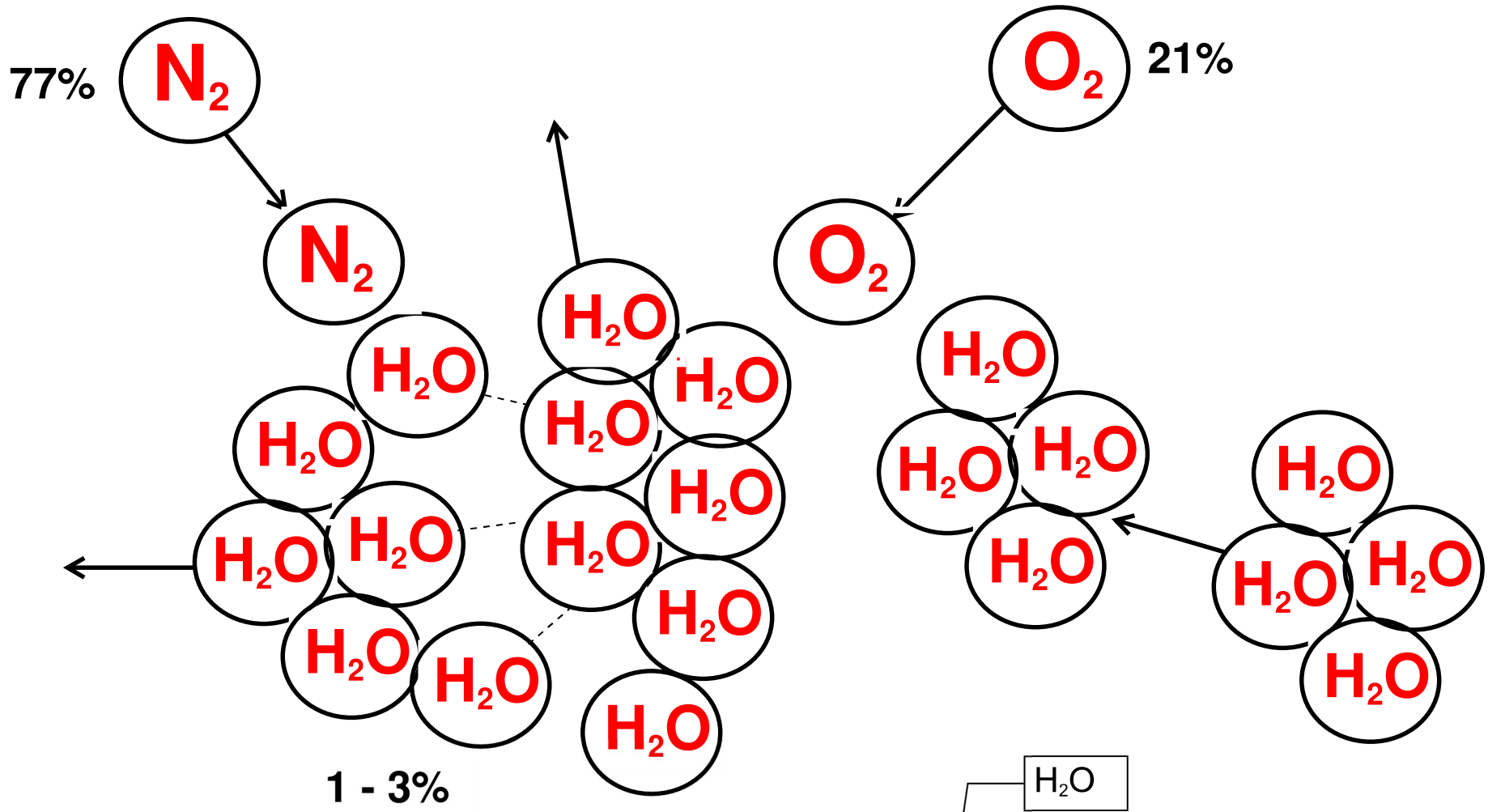

Relative Humidity

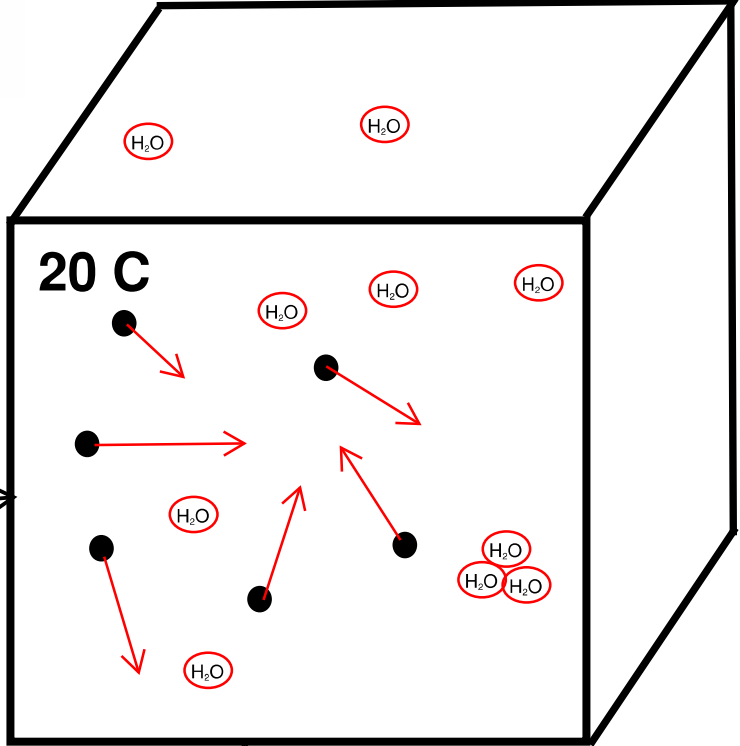
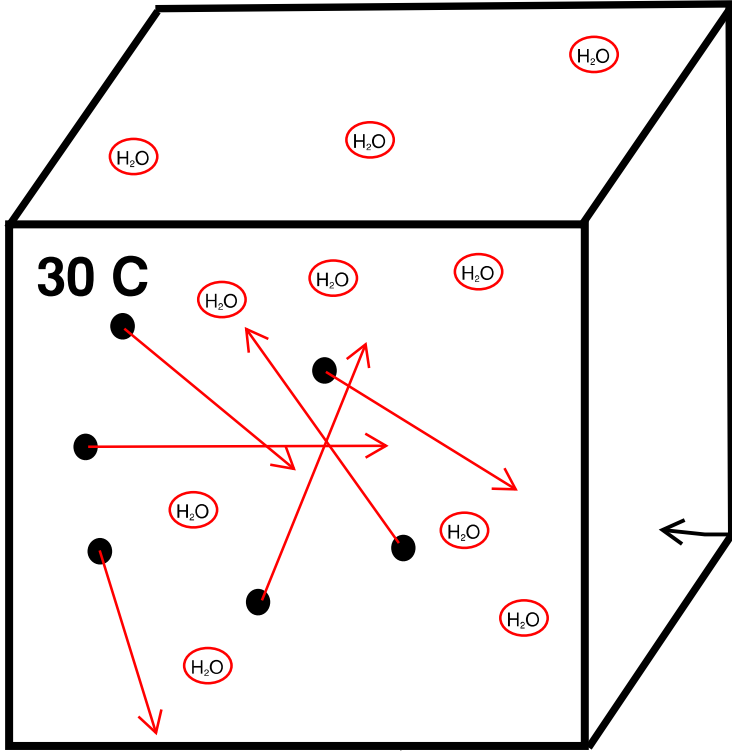

max 1000
molecules in
box before
water droplets
started forming

RH = 10%

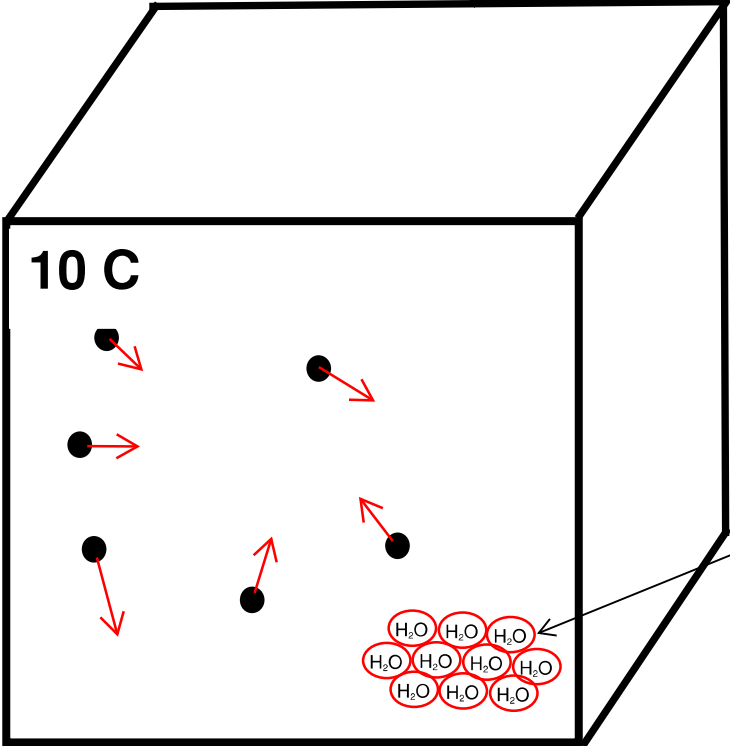

max 200
molecules in
box before
water droplets
started forming

RH = 50%

max 100
molecules in
box before
water droplets
started forming

RH = 100%

Dew Point Temperature (RH = 100%)

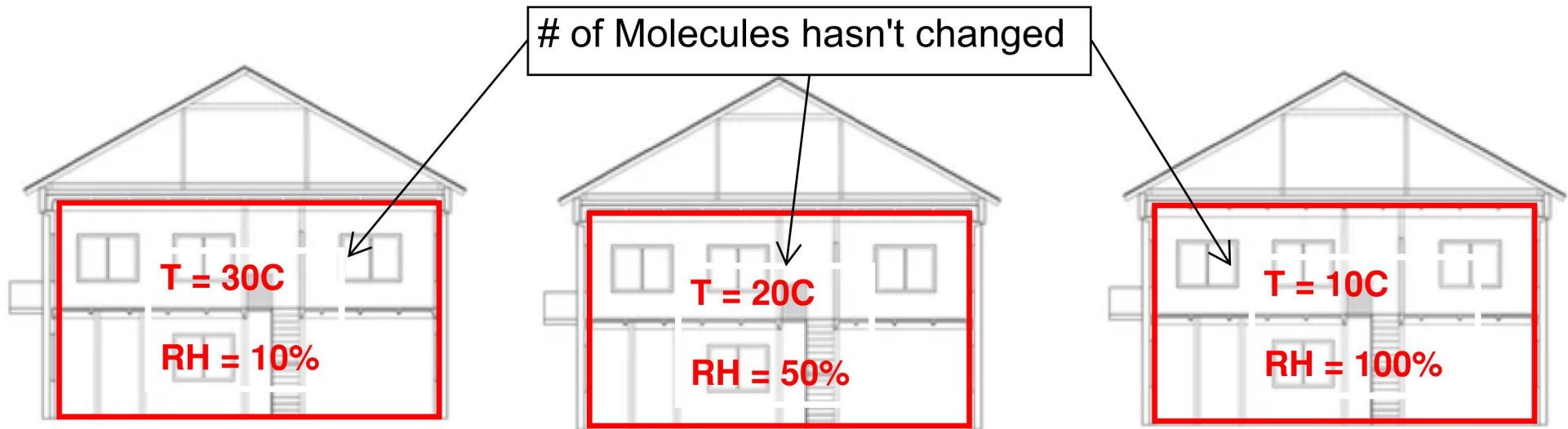
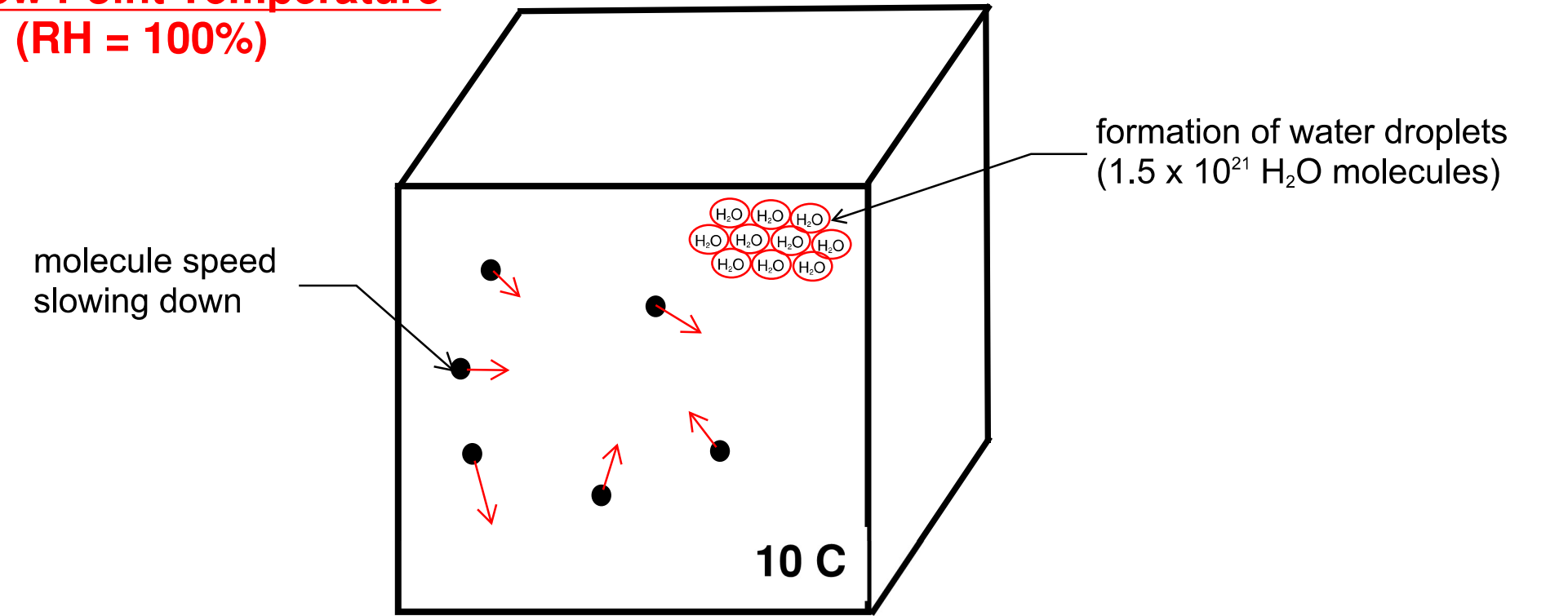

Temperature Decreases → RH Increases

Examples around Us



dew forms
as temperature drops

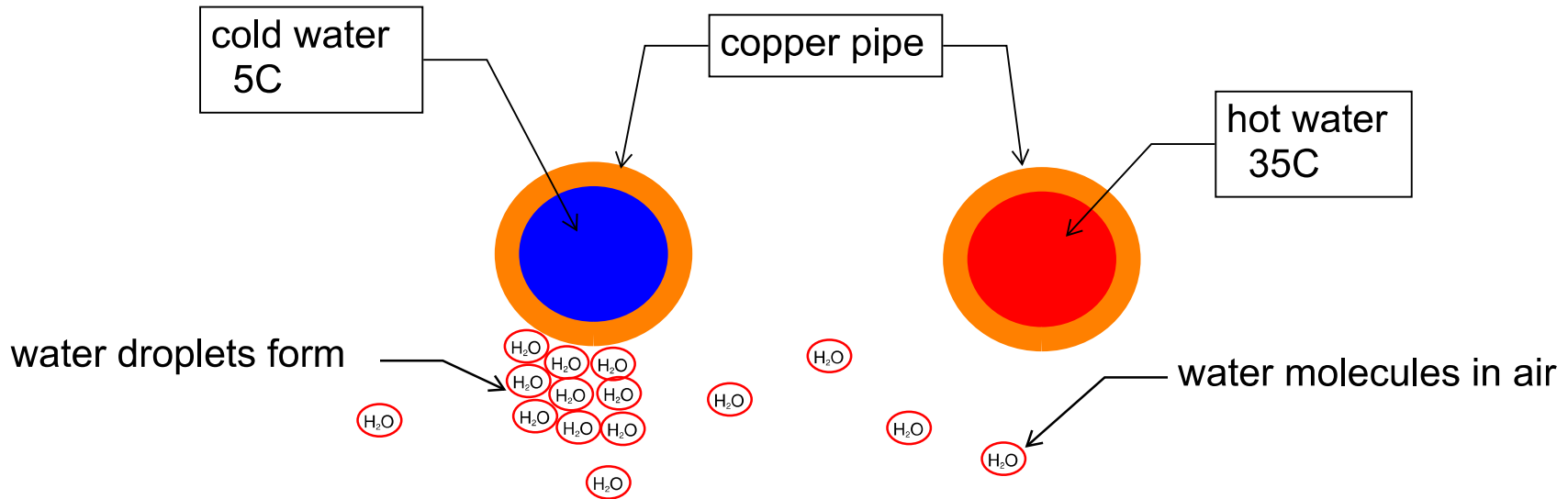

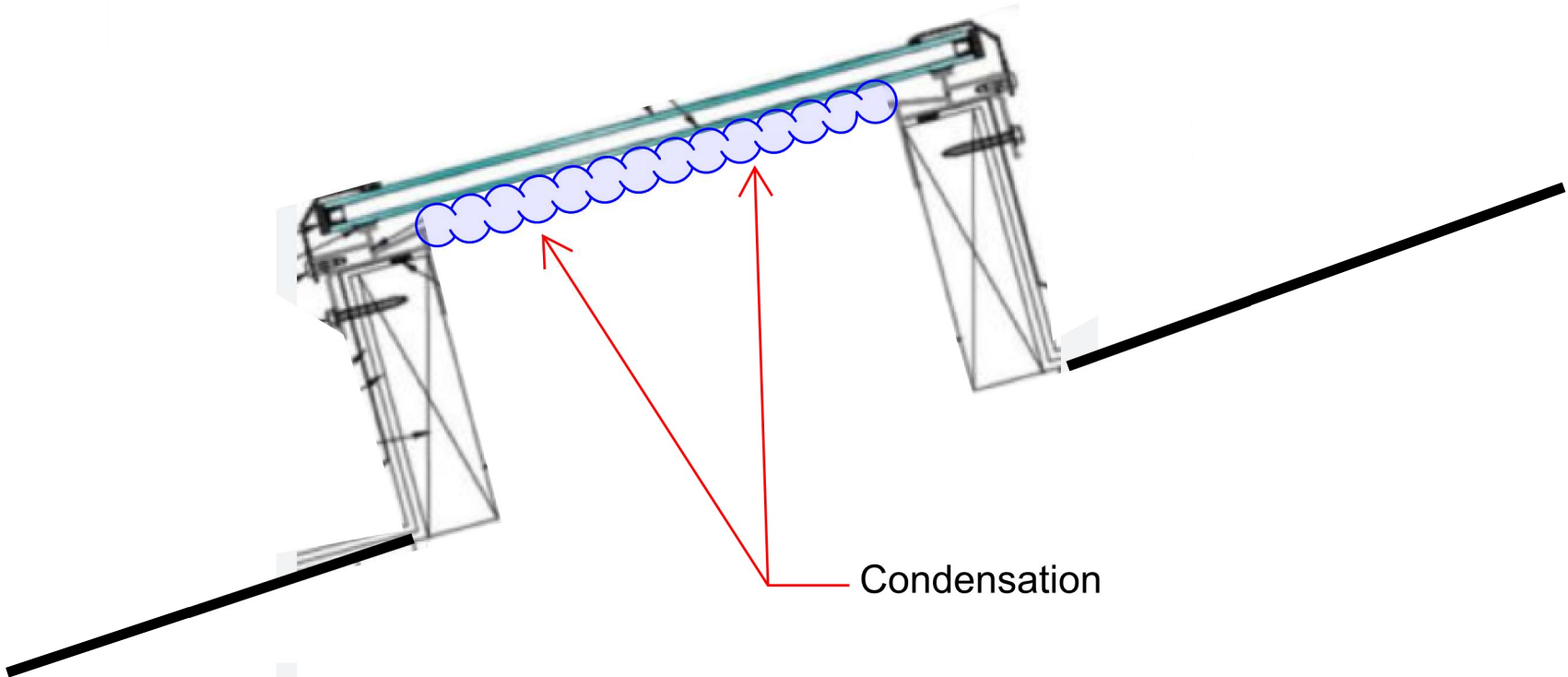



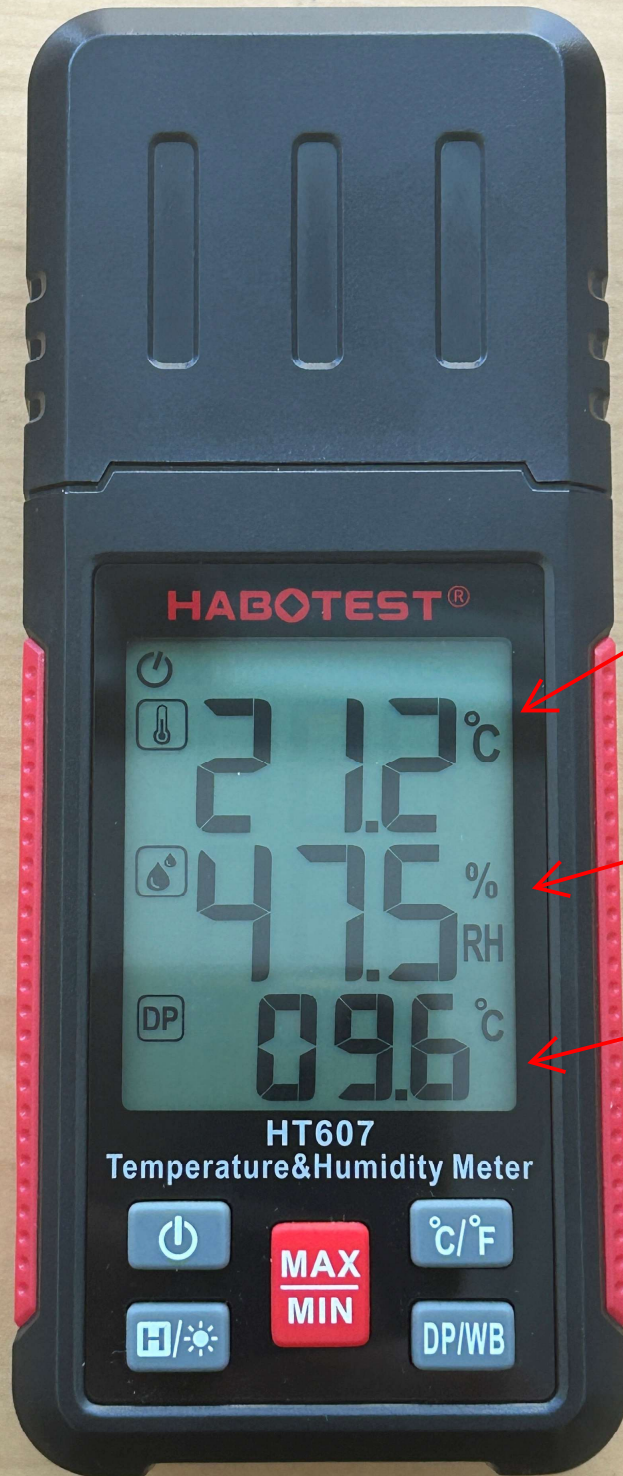

Temperature = 21.2C
"dry bulb temperature"

Relative Humidity
RH = 47.5 %

Dew Point Temperature
DPT = 9.6C

Air Leakage = holes (92% +/-) & gaps (4% +/-) & laps (3% +/-) & air diffusion (1% +/-)

75 Pa = 1.56 psf
(internal pressure)

Holes (or punctures)

Elements
(or components)
- sheets
- panels
- solid materials

Laps

Element Gaps
(or Joints)

Air Diffusion
(air permeance)

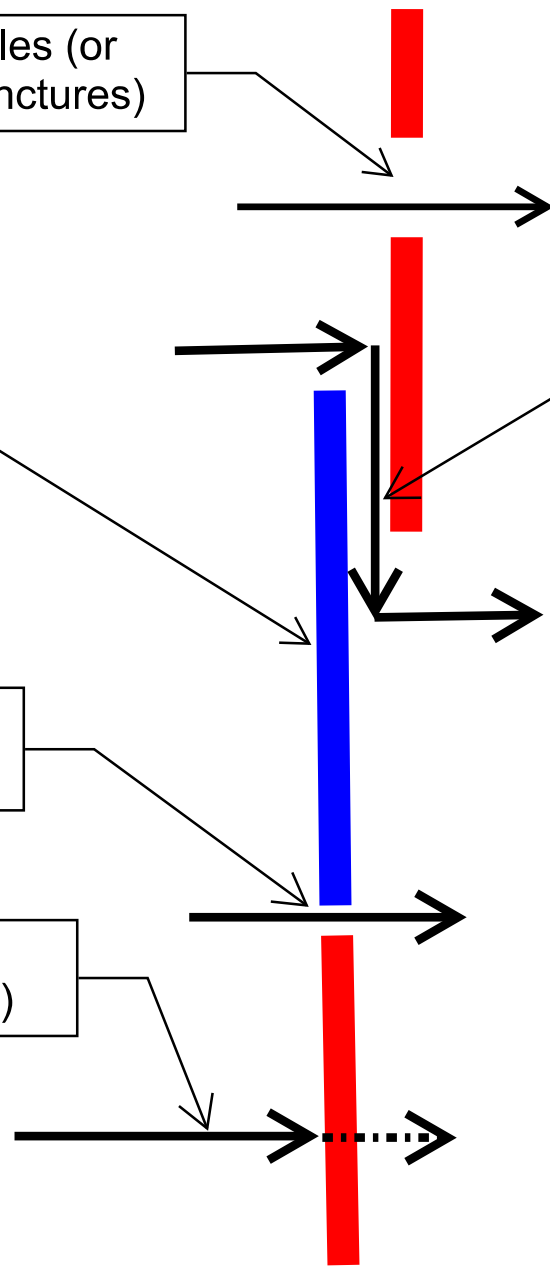

Air Diffusion (air permeance)

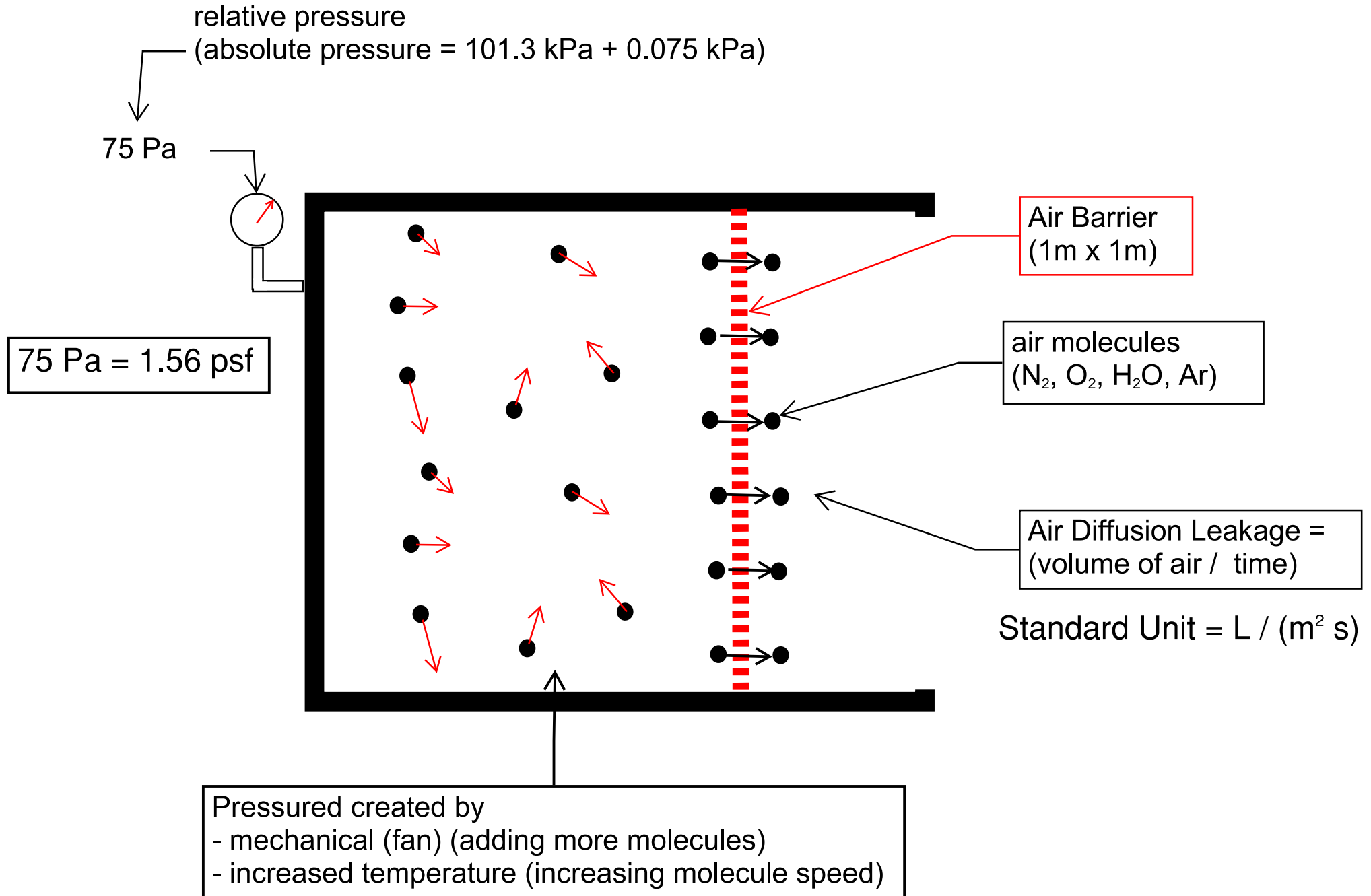

**(Water) Vapour Diffusion
 (vapour permeance)
 (water vapour permeance)**

Pressured created by either
 - increased humidity (adding more H₂O molecules)
 - increased temperature (increasing molecule speed)

580 Pa

increased vapour pressure

T = 20C
 RH = 50%
 VP = 1160 Pa = 580 + 580

T = 20C
 RH = 25%
 VP = 580 Pa

Vapour Barrier
 (1m x 1m)

water molecules
 (H₂O)

Vapour Diffusion Leakage =
 (volume of liquid water / time)

Increase in Vapour Pressure

Same ratio N₂
 & O₂ molecules

Standard Unit = ng / (m² s Pa)

Increase in Vapour Pressure

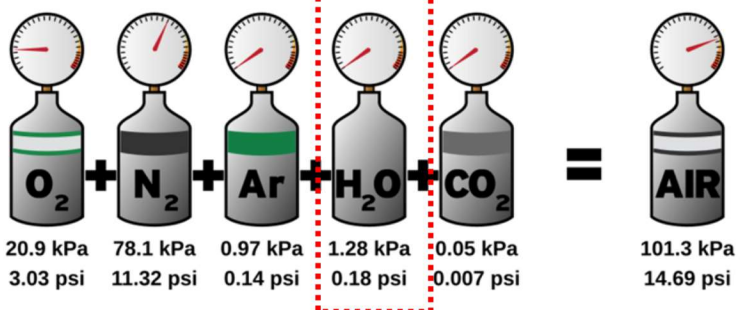

60 ng = 0.000000060 g
 1 gram = mass of small paper clip

1 US Perm = 57 ng / (m² s Pa)

No Vapour Barrier

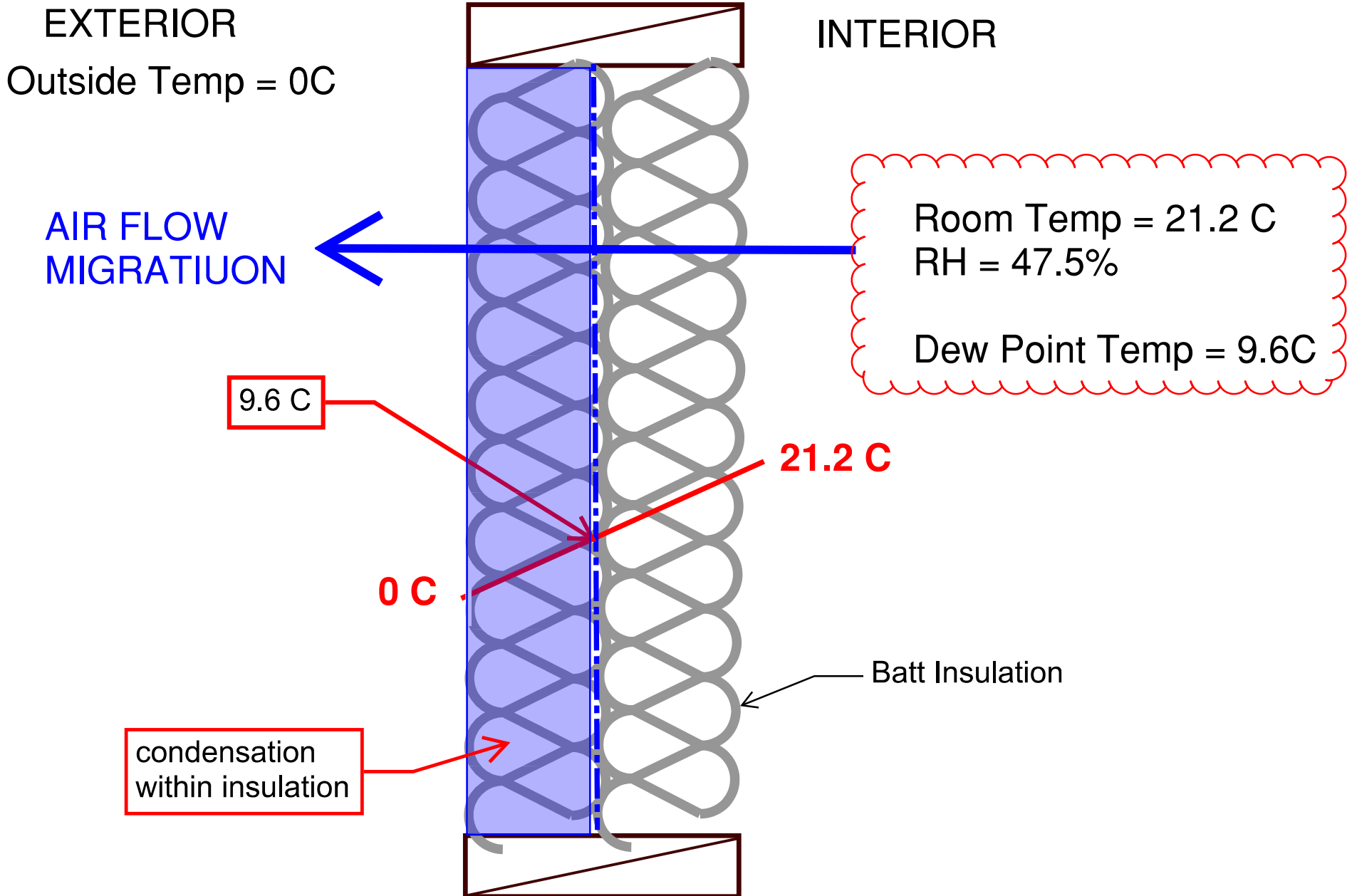

Building Envelope & Moisture Control

Vapour Barrier on warm side

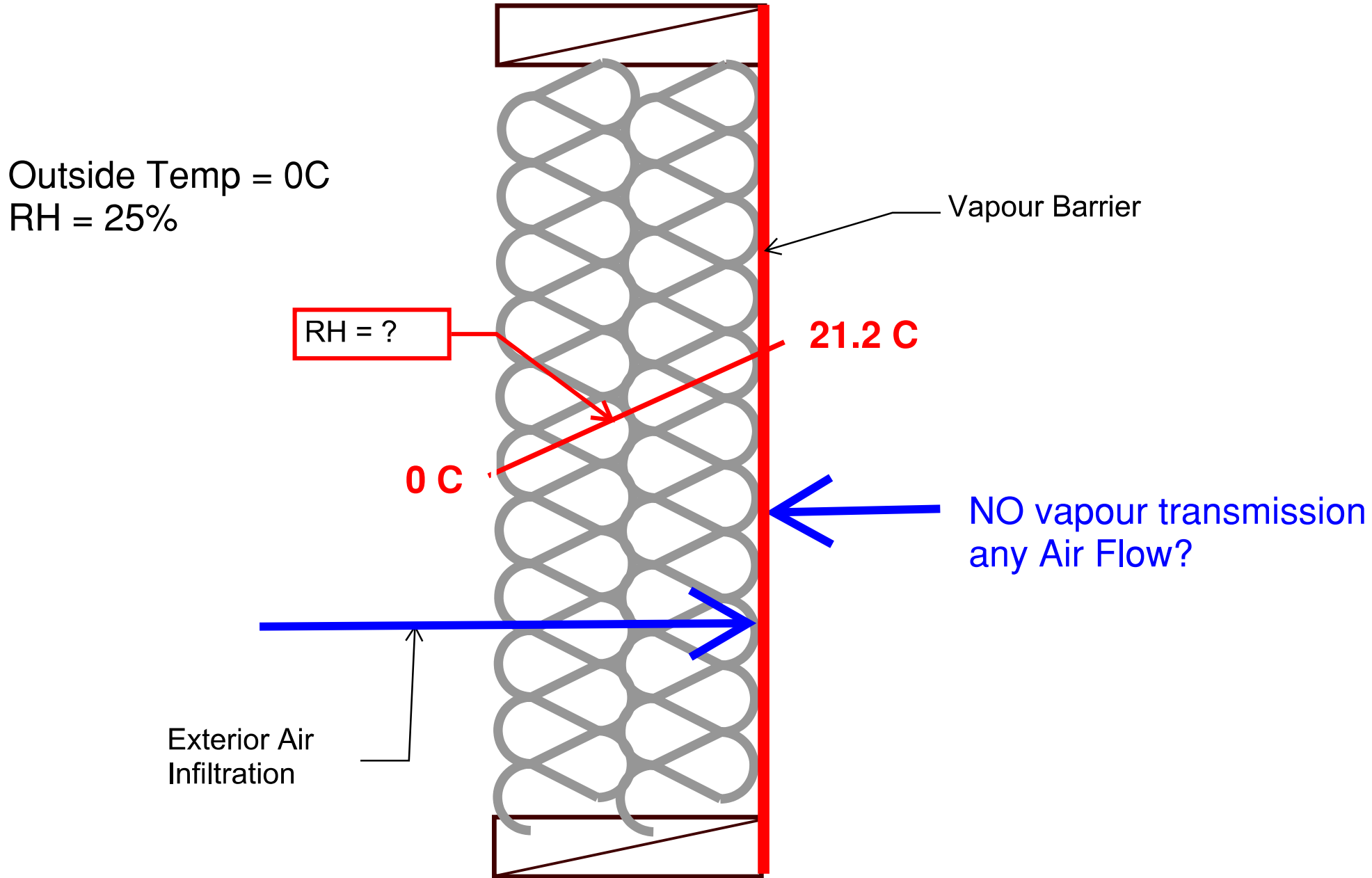

Vapour Barrier on cold side

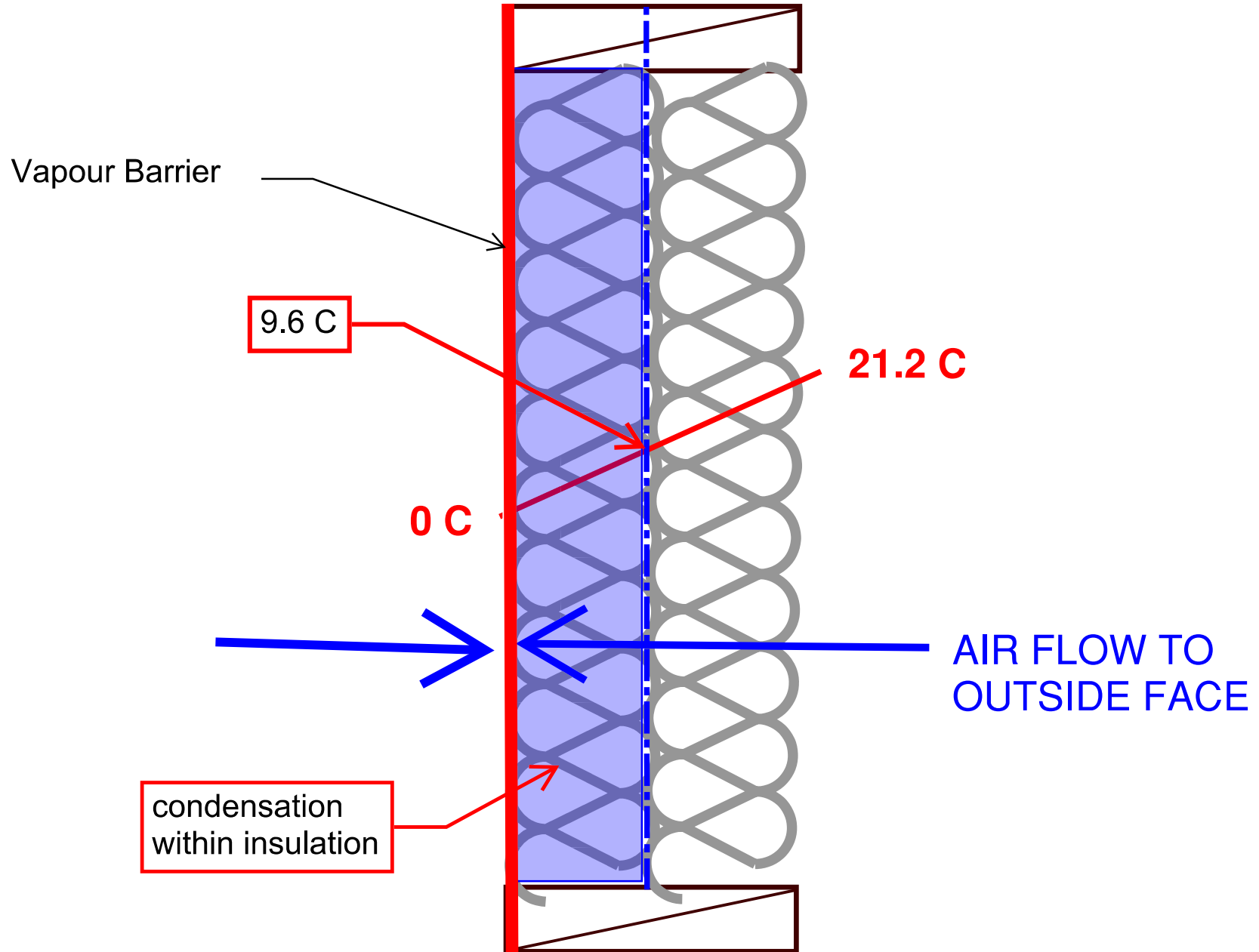

Vaour Barriers (Always on Warm Side of DPT)

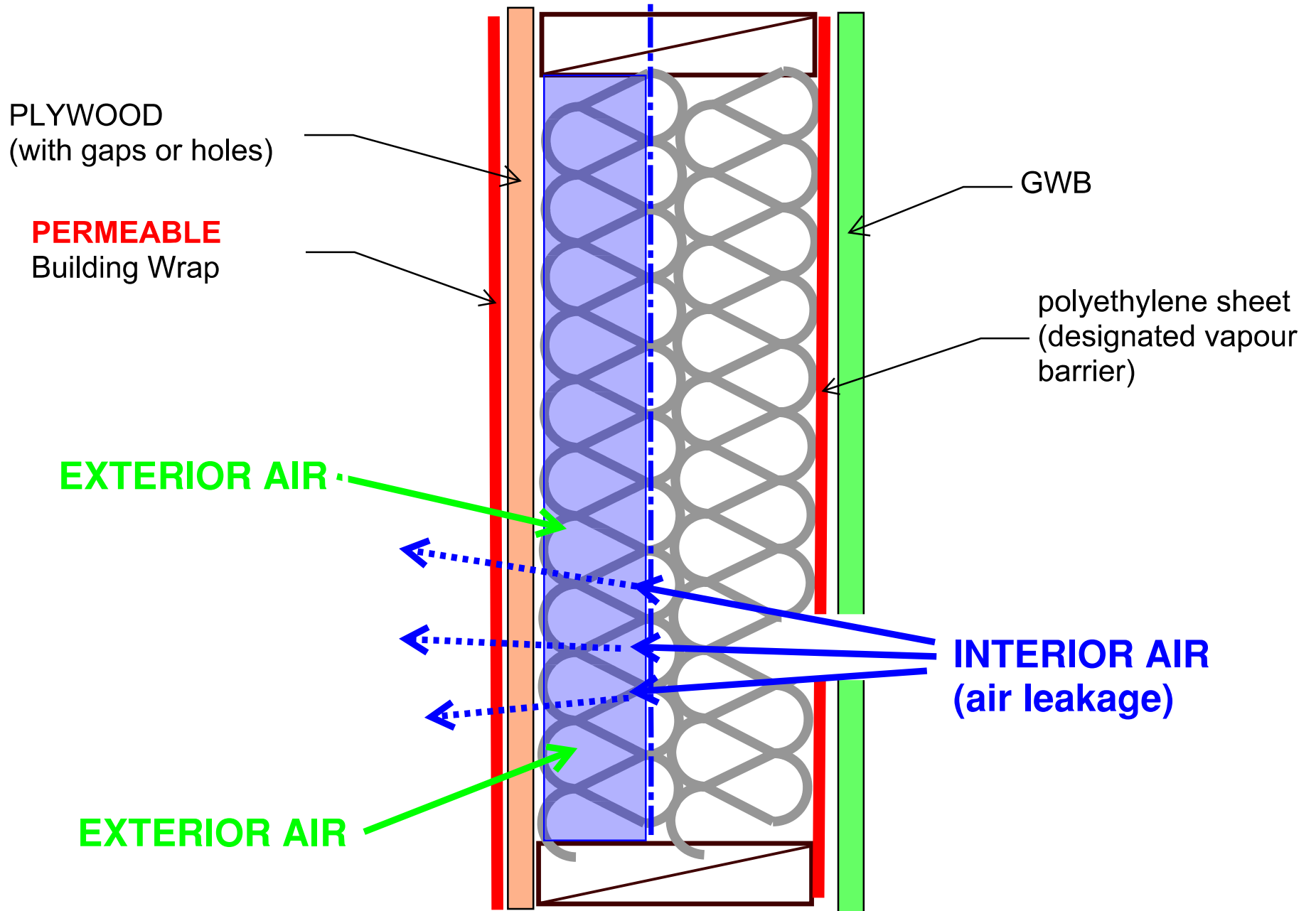

Double Vapour Barriers

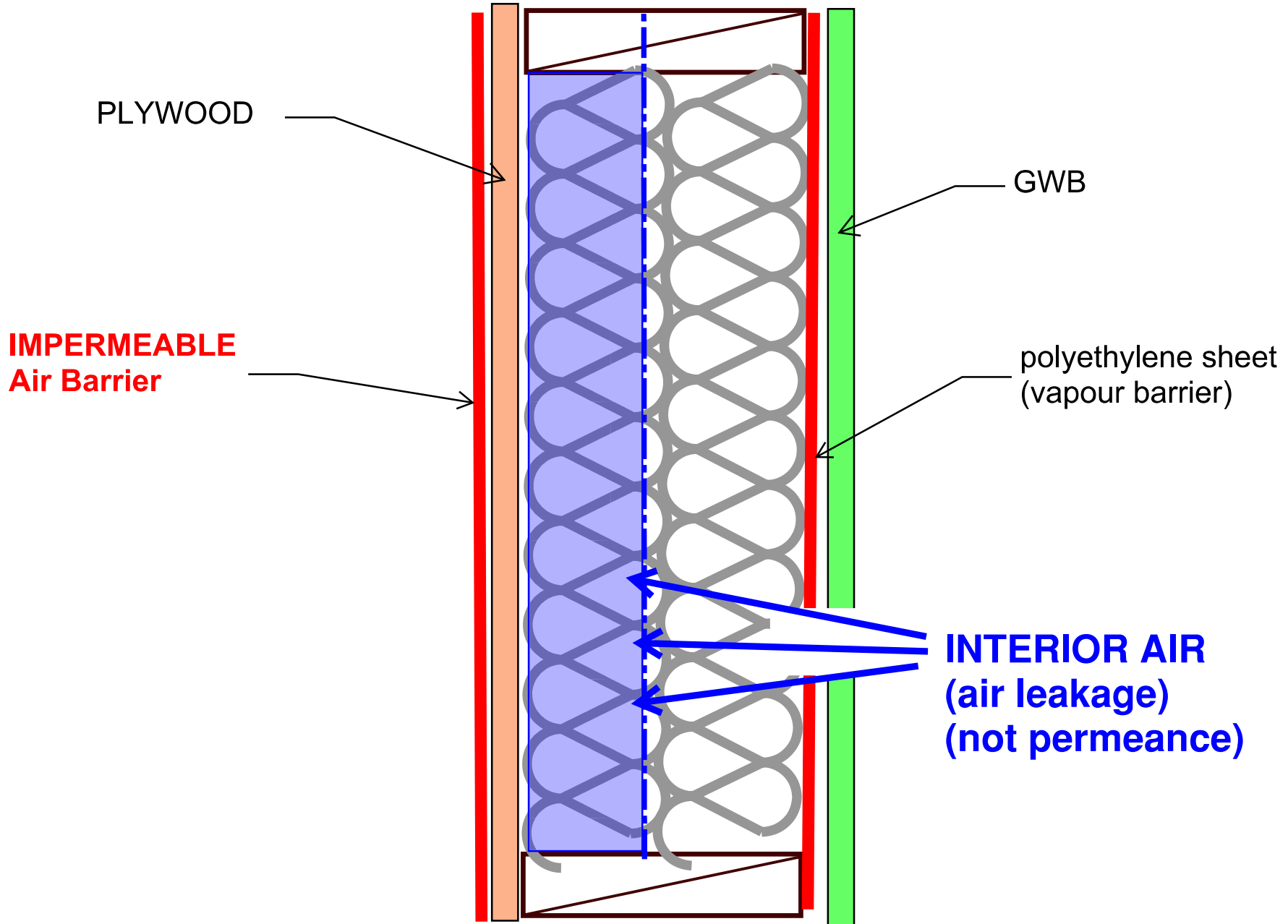

Double Vapour Barriers

Another Common Example

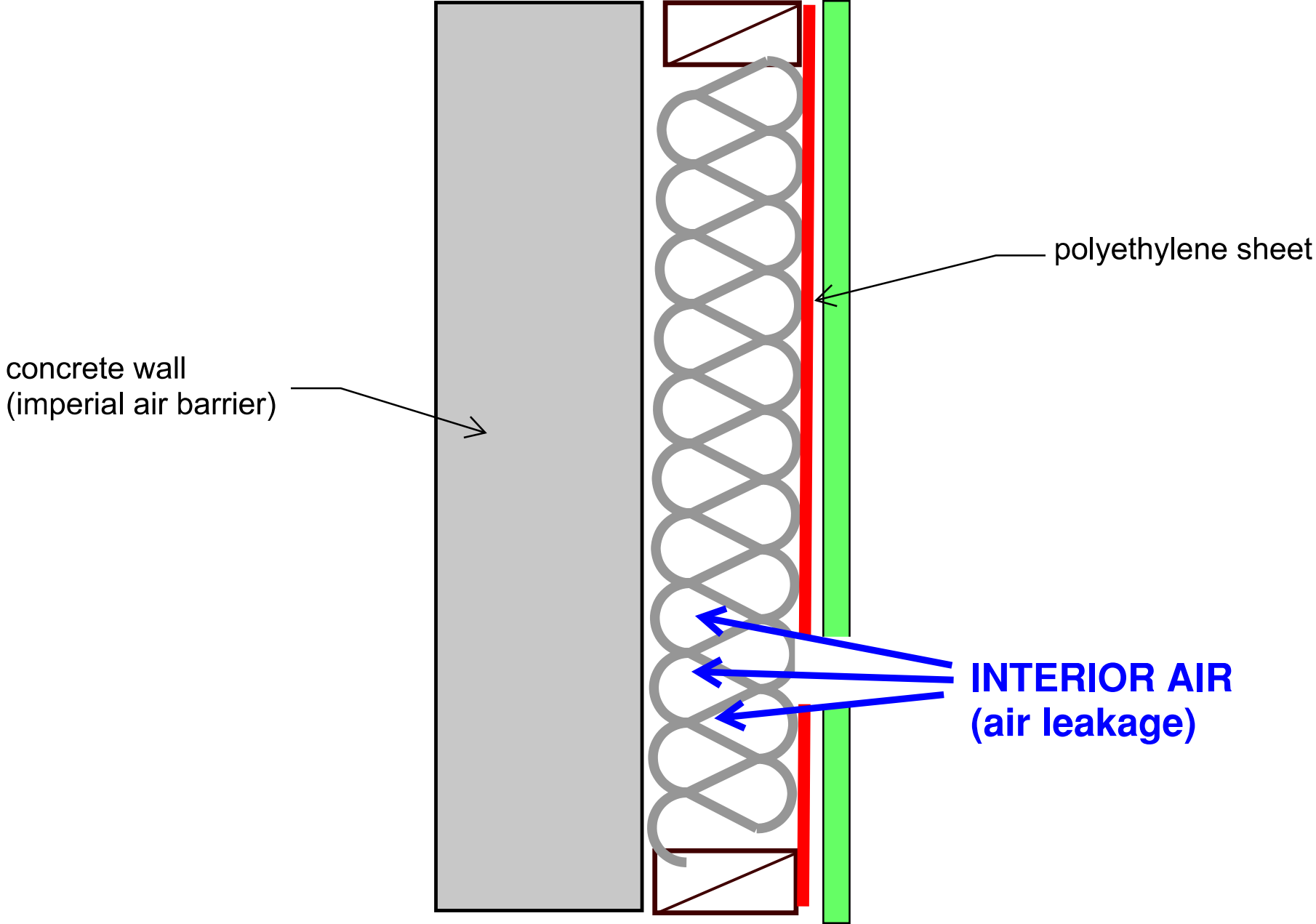

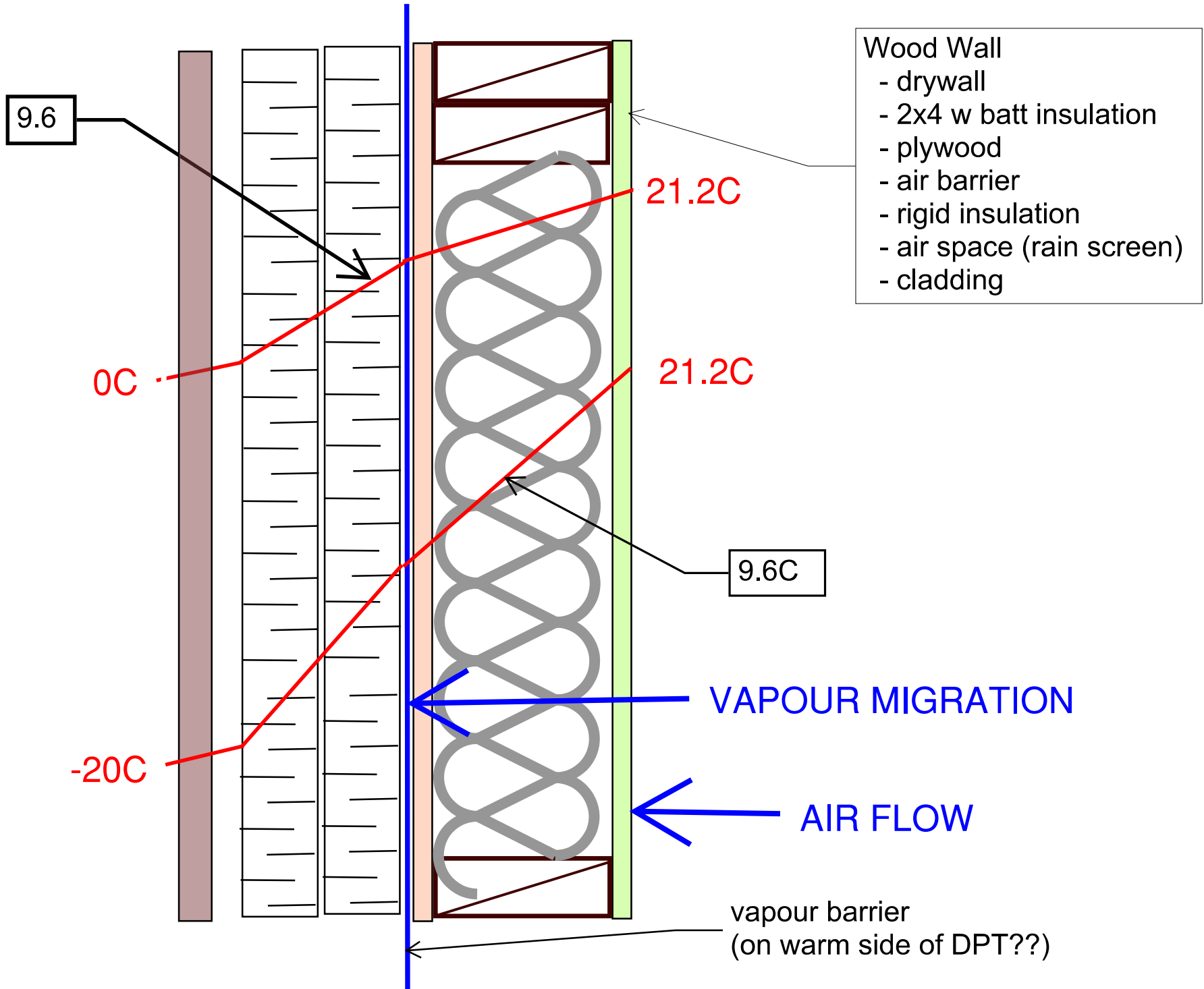

9.25.5.1. General

(See Note A-9.25.5.1.)

- 1)** Except as provided in Sentences (2) to (4), sheet and panel-type materials incorporated into assemblies described in Article 9.25.1.1. shall conform to Article 9.25.5.2., where
 - a) the material has
 - i) an air leakage characteristic less than $0.1 \text{ L}/(\text{s}\times\text{m}^2)$ at 75 Pa, and
 - ii) a water vapour permeance less than $60 \text{ ng}/(\text{Pa}\times\text{s}\times\text{m}^2)$ when measured in accordance with ASTM E96/E96M, "Standard Test Methods for Water Vapor Transmission of Materials" using the desiccant method (dry cup) (see Note A-9.25.5.1.(1)(a)(ii)), and
 - b) the intended use of the interior space where the materials are installed will not result in high moisture generation.

9.36.2.9. Airtightness

- 1)** The leakage of air into and out of *conditioned spaces* shall be controlled by constructing
 - a) a continuous *air barrier system* in accordance with Sentences (2) to (6), Subsection 9.25.3. and Article 9.36.2.10.,
 - b) a continuous *air barrier system* in accordance with Sentences (2) to (6) and Subsection 9.25.3. and a *building* assembly having an air leakage rate not greater than $0.20 \text{ L}/(\text{s}\times\text{m}^2)$ (Type A4) when tested in accordance with CAN/ULC-S742, "Standard for Air Barrier Assemblies – Specification" at a pressure differential of 75 Pa, or

Air Barrier Criteria

- maximum Air Leakage Rate?
 - continuous
 - sufficient structural strength (to resist air pressures)
 - flexible (for bldg movement)
 - durable over time (especially caulking)
 - buildable / constructible
-
- low vapour permeance???
 - on cold side of insulation?

Adfreezing means the adhesion of *soil* to a *foundation unit* resulting from the freezing of *soil* water. (Also referred to as “frost grip.”)

Air barrier system means the assembly installed to provide a continuous barrier to the movement of air.

Air-supported structure means a structure consisting of a pliable membrane that achieves and maintains its shape and support by internal air pressure.

Air Barrier System & Wall Assembly

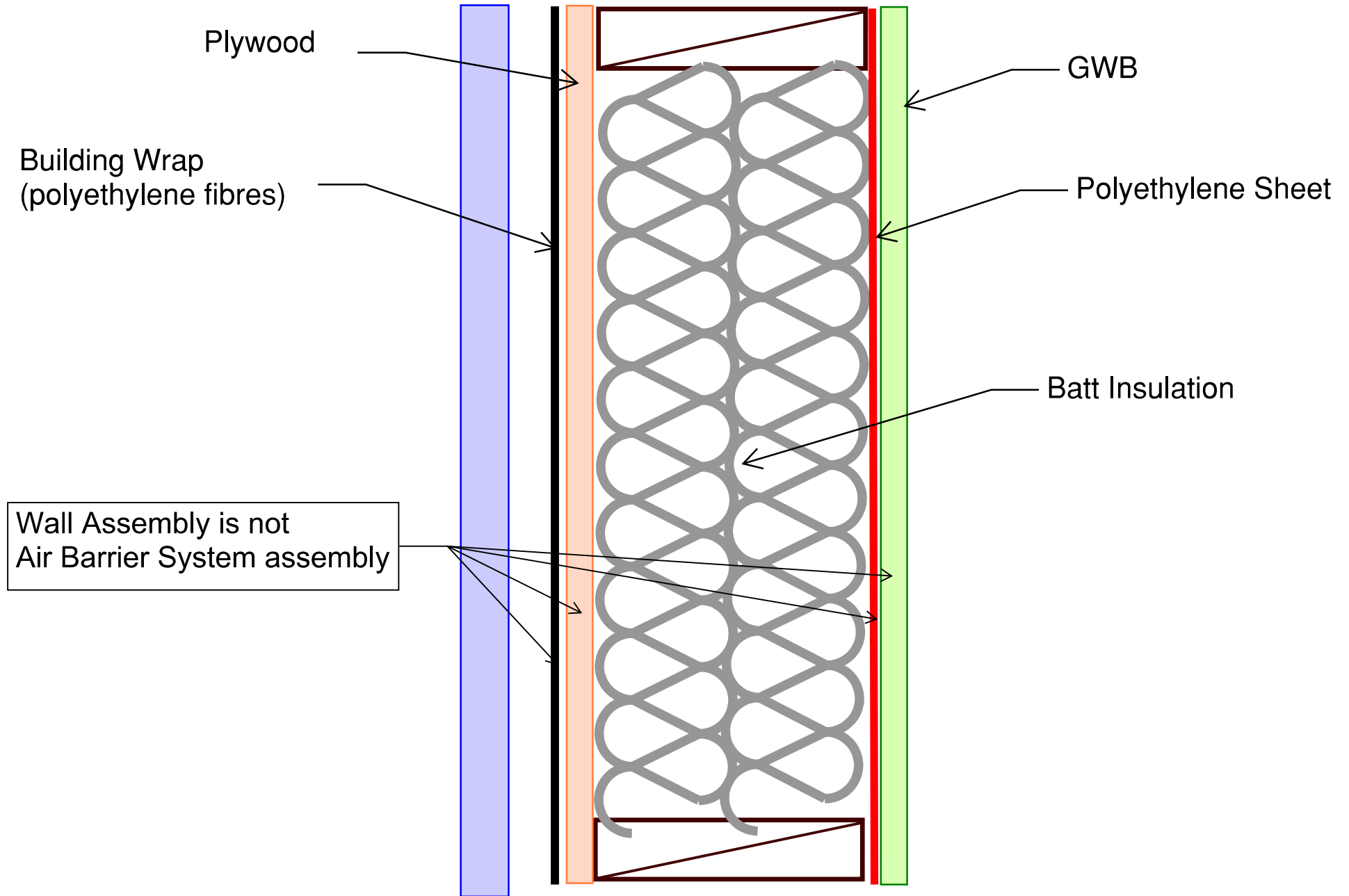

Air Barrier SYSTEM

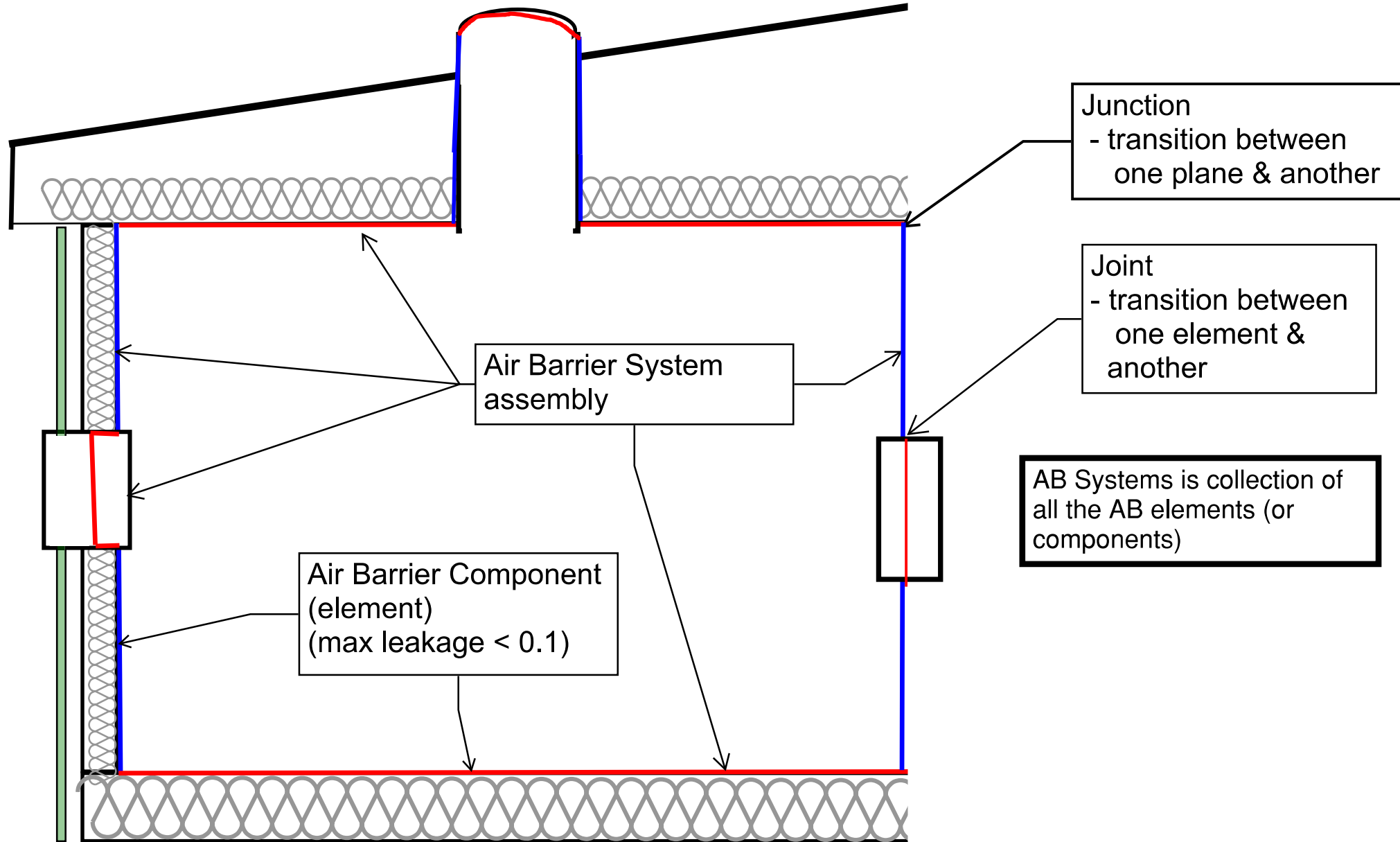

Air Barrier Continuity

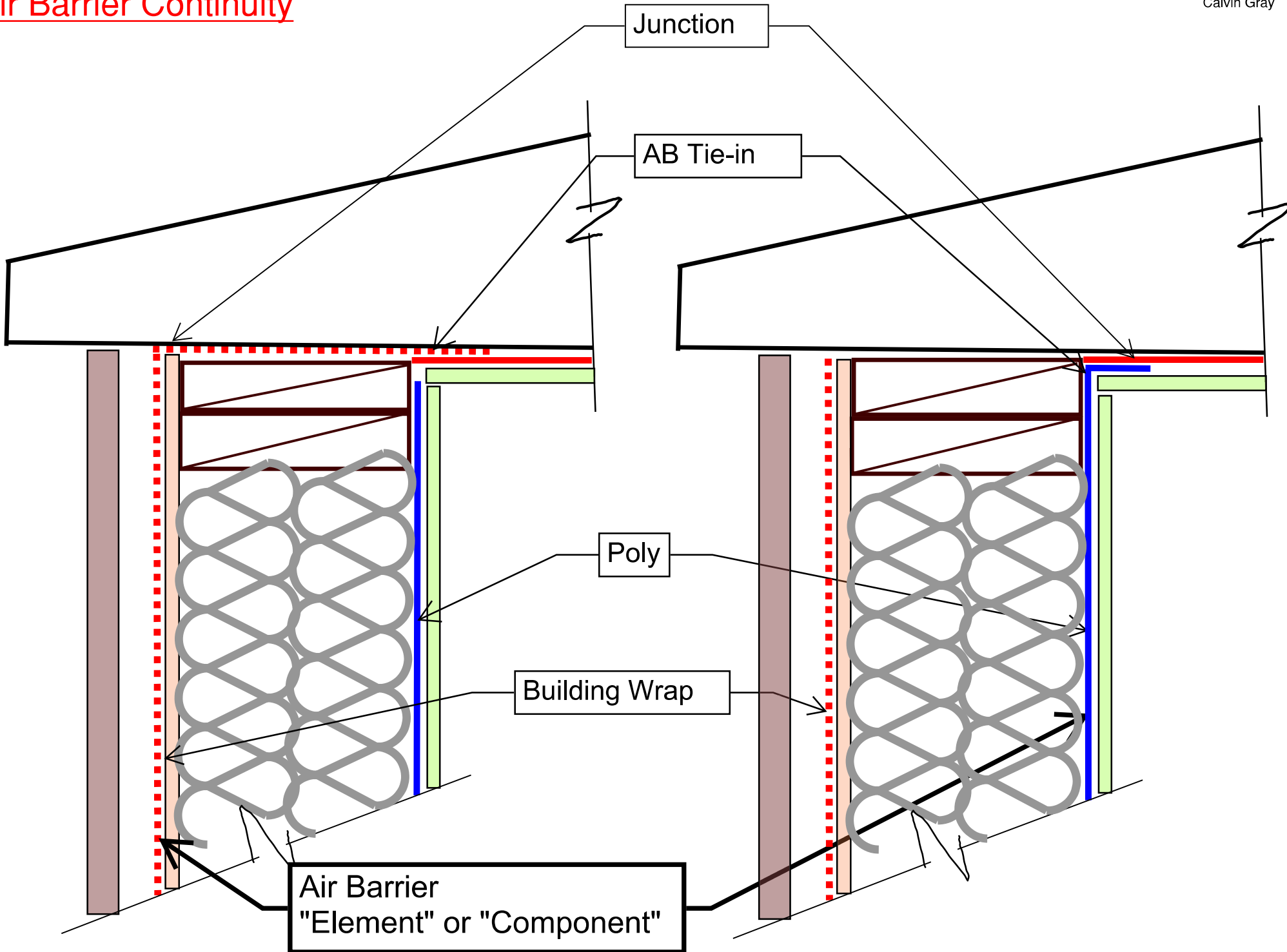

Air Barrier Continuity

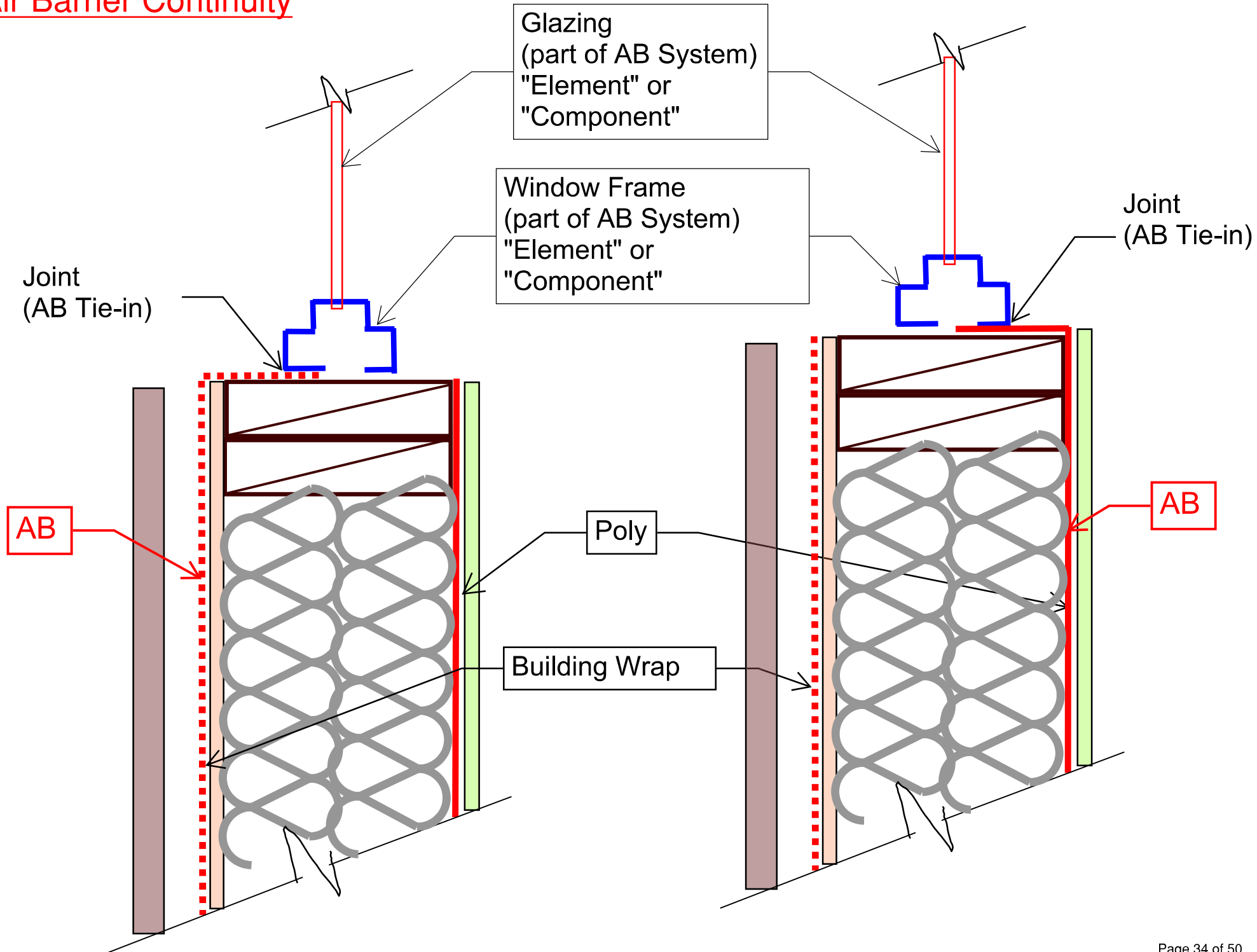

Materials NOT adequate as AB

Table 6. Air and vapour permeance data for common construction materials

Material	Air Permeance Measured Leakage 75 Pa L/(s•m ²)
Construction Materials	
9.50-mm (3/8-in.) plywood sheathing	0.00
8.00-mm (5/16-in.) plywood sheathing	0.0067
15.9-mm (5/8-in.) flakewood board (OSB)	0.0069
11.0-mm (7/16-in.) flakewood board (OSB)	0.0108
15.9-mm (5/8-in.) particle board	0.0260
12.7-mm (1/2-in.) particle board	0.0155
12.7-mm (1/2-in.) cement board	0.00
11.0-mm (7/16-in.) plain fibreboard	0.8223
11.0-mm (7/16-in.) asphalt impregnated fibreboard	0.8285
3.00-mm (1/8-in.) hardboard (standard)	0.0274
12.7-mm (1/2-in.) foil back gypsum board	0.00
12.7-mm (1/2-in.) gypsum board	0.0091
Tongue and groove planks	19.1165
2.70-mm (3/32-in.) modified bituminous torch on grade membrane (polyester reinforced mat)	0.00
2.70-mm (3/32-in.) modified bituminous torch on grade membrane (glass fibre mat)	0.00
1.50-mm (1/16-in.) modified bituminous self-adhesive membrane	0.00
1.50-mm (1/16-in.) smooth surface roofing membrane	0.00
13.6-kg (30-lb) roofing felt	0.1873
6.8-kg (15-lb) non-perforated asphalt felt	0.2706
6.8-kg (15-lb) perforated asphalt felt	0.3962
Plastic and Metal Foils and Films	
0.15-mm (6-mil) polyethylene	0.00
0.03-mm (1-mil) aluminum foil	0.00
Reinforced non-perforated polyolefin	0.0195
Spunbonded polyolefin film	0.9593
Spunbonded polypropylene film	3.2186
0.10-mm (4.00-mil) Type I perforated polyethylene	4.0320
0.10-mm (4.00-mil) Type II perforated polyethylene	3.2307
Thermal Insulations	
38.0-mm (1.5-in.) extruded polystyrene	0.00
25.4-mm (1-in.) foil back urethane insulation	0.00
25.4-mm (1-in.) phenolic insulation board	0.00
50.8-mm (2-in.) phenolic insulation board	0.00
25.0-mm (1-in.) expanded polystyrene - Type II	0.1187
Glass fibre rigid insulation board with spunbonded polyolefin film on one face	0.4880
25-mm (1-in.) expanded polystyrene - Type I	12.2372
152-mm (6-in.) glass fibre wool insulation	36.7327
Vermiculite insulation	70.4926
Cellulose insulation (spray on)	86.9457

greater than
0.1 L / (s m²)
@ 75 Pa

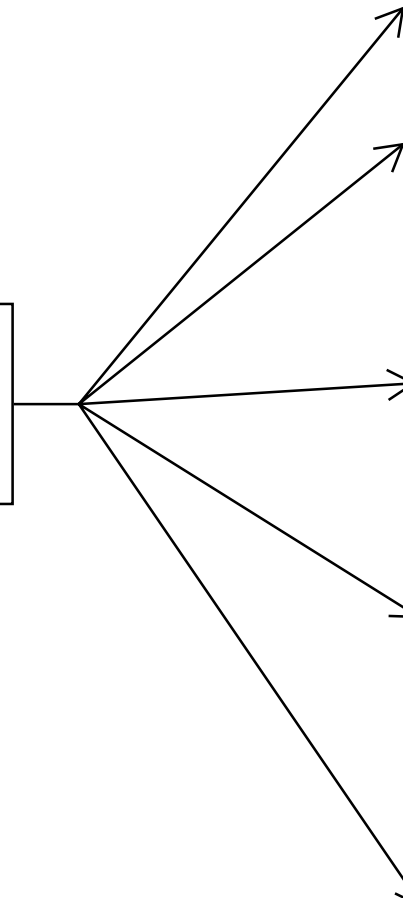

Materials adequate as an Air Barrier
less than 0.1 L / (s m²) at 75 Pa

- 3/8" plywood → air leakage = 0 L / (s m²)
- 7/16" OSB → 0.0108
- 1/2" particle board → 0.0155
- hardboard → 0
- 1/2" drywall → 0.0091
- modified bituthane torch on membrane → 0
- 6 mil polyethylene → 0
- building wrap → 0.02 to 0.05

- any other material with less than 0.1 L / (m² s)
(at 75 Pa pressure)

Which is the Air Barrier?

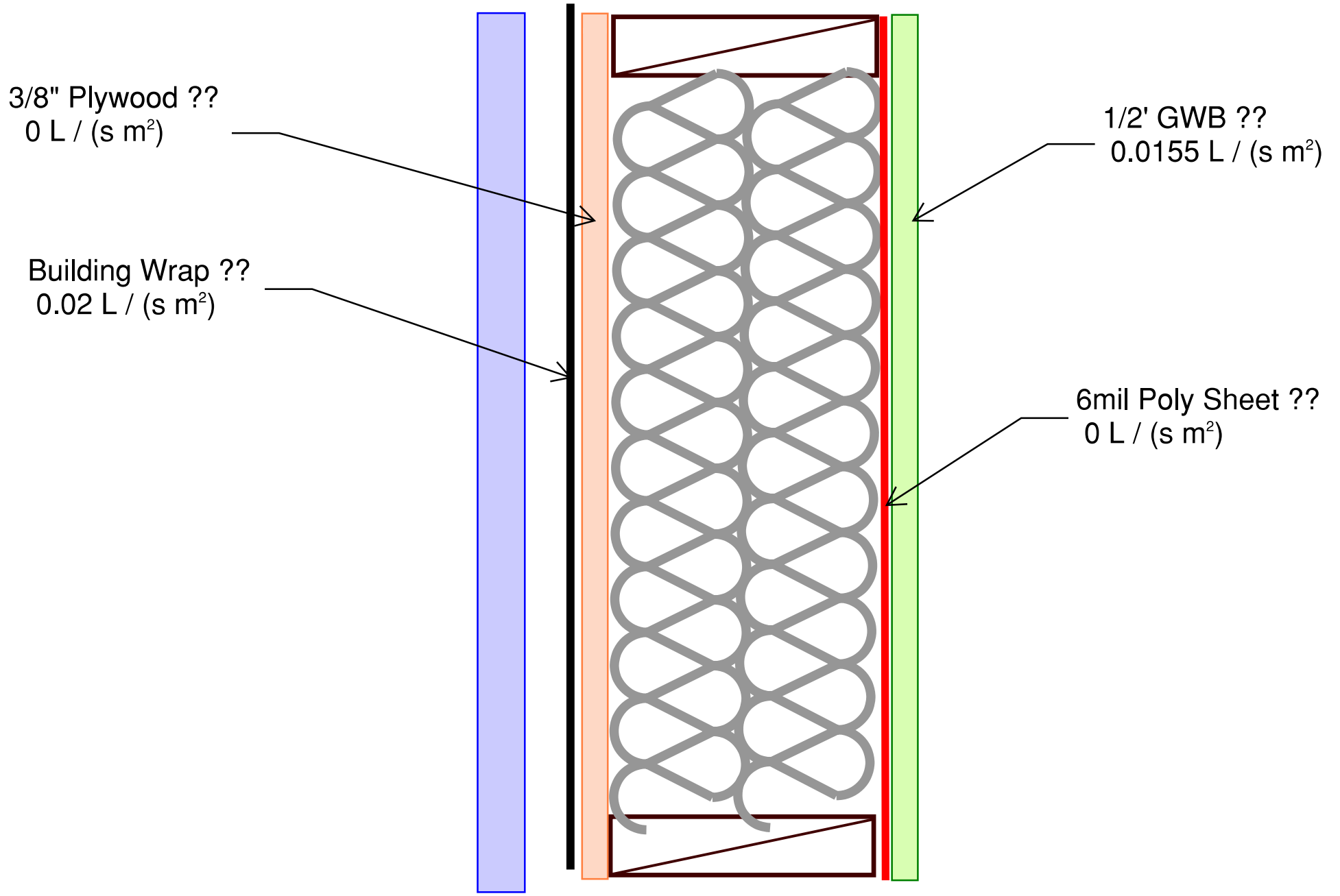

Energy Efficiency & Building Envelop

Goals

(1) reduce conductive heat loses
(increase R value)

(2) **convective heat loses**
(for air barrier system reduce
air losses $< 0.2 \text{ L} / (\text{m}^2 \text{ s})$)



**AIR LOSS
= HEAT LOSS**

**EXTERIOR
(0 C)**

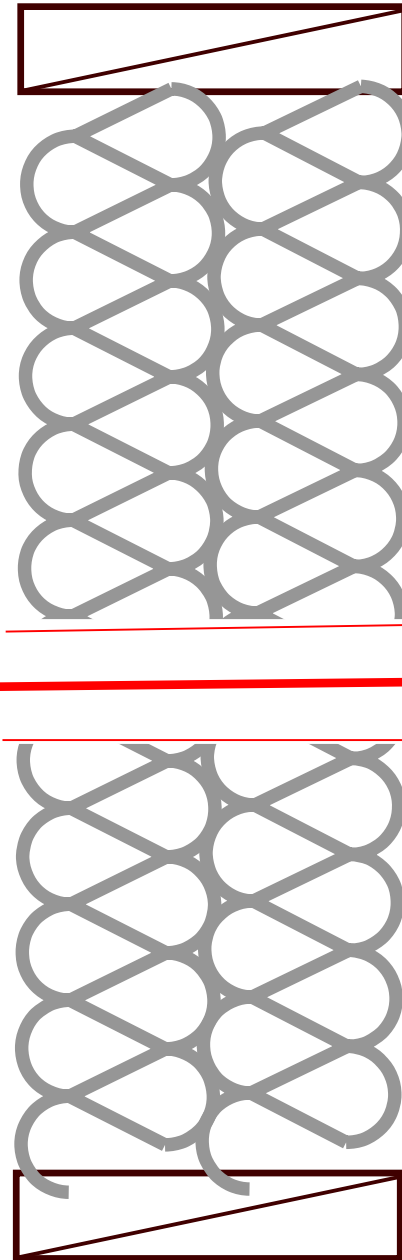

**AIR LOSS
= HEAT LOSS**

**INTERIOR
(21.2C)**

Blower Door Test

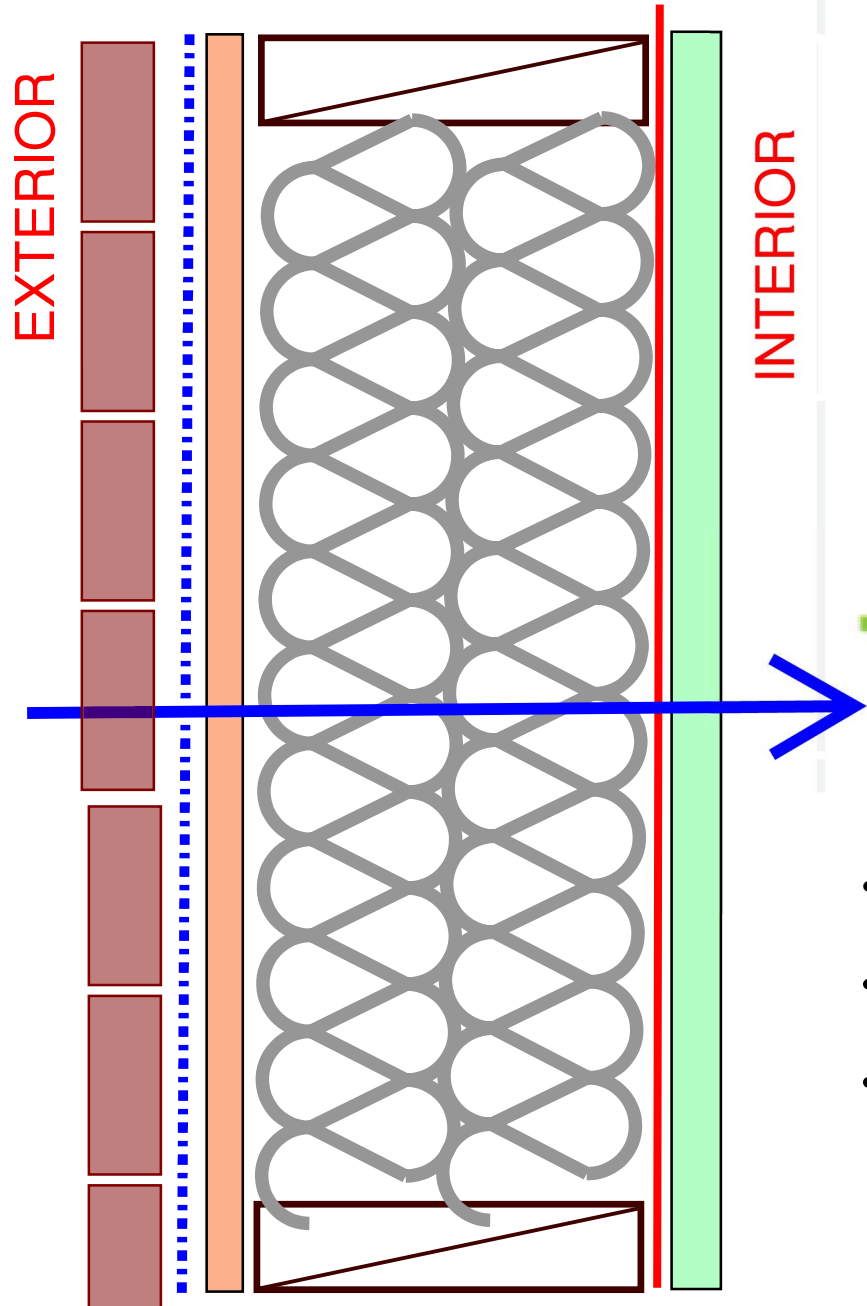

- tests the overall air barrier **system**
- negative air pressure created within space (not exfiltration)
- in reality - tests all barriers (plywood, poly, batt & drywall) that might resist infiltration air leakage (not only the "designated" air barrier)

Building Wrap as AB



40ft x40ft building
 1600 sq ft house

Building Wall Area
 (8ft x 40ft x 4)
 $A = 1280 \text{ ft}^2 = 119 \text{ m}^2$
 $V = 12,800 \text{ ft}^3 = 363 \text{ m}^3$

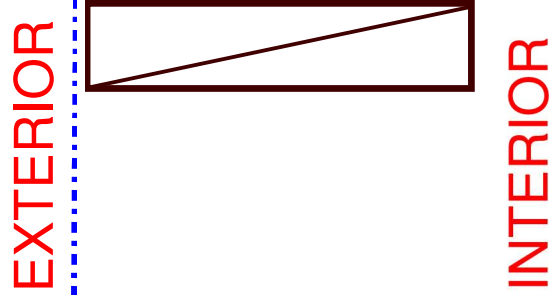

Building Wrap as designated "air barrier"

max air leakage rate permitted (by BCBC) < **0.1** L / (m² s) at 75 Pa
 (for the material)

Bldg Wrap Material < **0.05** L / (m² s)

Diffusion Leakage Alone = $(0.05) \times 119 \text{ m}^2 \times (60 \times 60) = \mathbf{21,420 \text{ L / hr}}$
 $(1000 \text{ L} = \text{m}^3) = \mathbf{21.42 \text{ m}^3 / \text{hr}}$
 (through walls alone by diffusion)

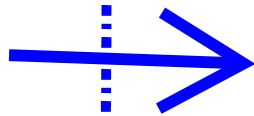

Diffusion Leakage

COMMON BUILDING WRAP CLAIM

• **Air Permeability:** Higher than required by codes, allowing moisture vapor to pass while resisting air.

??

YES



Comparison of Annual Diffusion Rates

Air Diffusion = 0.1 L / (m² s) (at 75 Pa)
= 3,153,600 L / m² per year (at 75 Pa)
= **3153.6 m³ of air / m² per year**

3153.6 m³ = 14.66m x 14.66m x 14.66m
= 48 ft x 48ft x 48ft

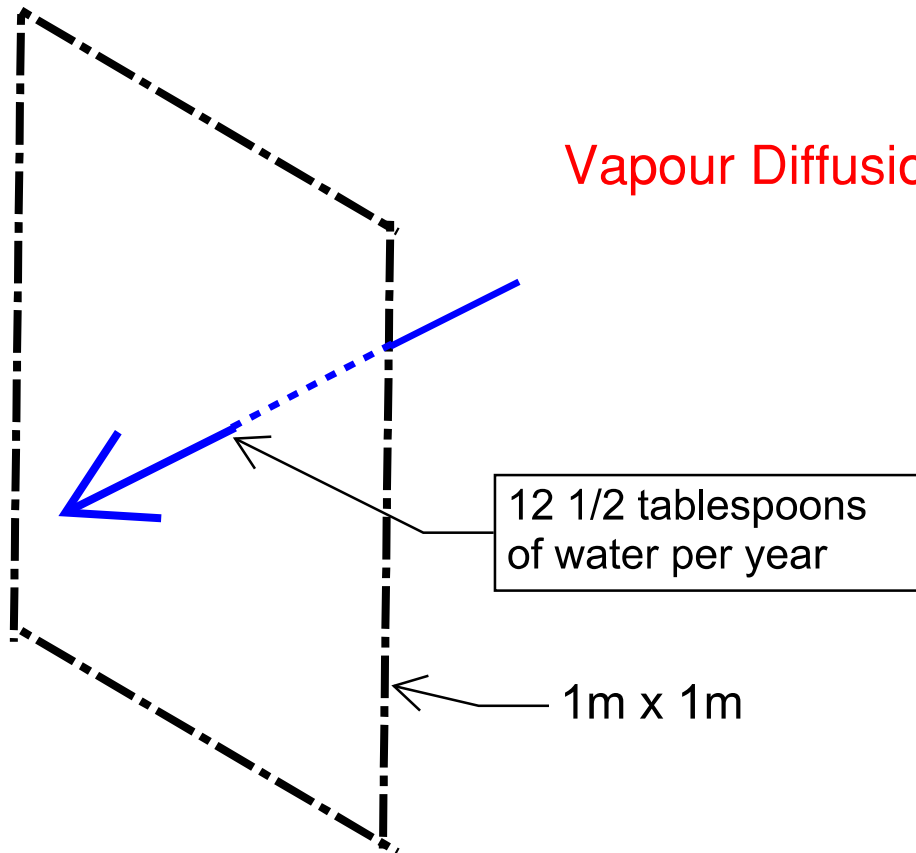

Vapour Diffusion = 60 ng / (Pa s m²)
= $\frac{(60 \times 100 \times 60 \times 60 \times 24 \times 365)}{(1,000,000,000)}$
= 189 g / m² per year (at 100 Pa)
= **12.5 tablespoons of water / m² per year**

Volume of Air leaked
in 1 m² of material per year

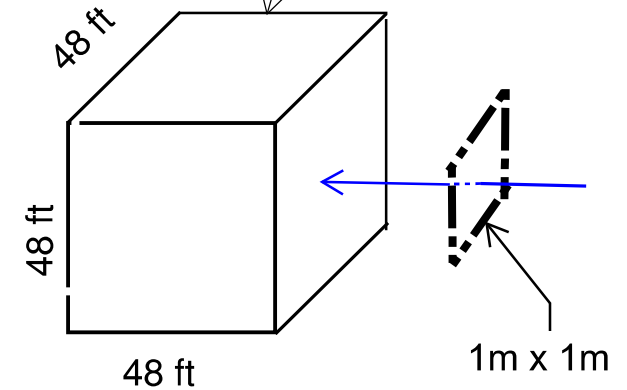

Acceptable Vapour Barriers Materials

< 60 ng / (Pa s m²)

1 US Perm = 57.2 ng / (Pa s m²)

acceptable VB < 1 US Perm

Acceptable VB are also Acceptable AB

Not all Acceptable AB are Acceptable VB examples

- building wraps
- drywall

Table 6. Air and vapour permeance data for common construction materials

Material	Air Permeance Measured Leakage 75 Pa L/(s•m ²)	Vapour Permeance ng/(Pa•s•m ²)
Construction Materials		
9.50-mm (3/8-in.) plywood sheathing	0.00	15-50
8.00-mm (5/16-in.) plywood sheathing	0.0067	18-59
15.9-mm (5/8-in.) flakewood board (OSB)	0.0069	30
11.0-mm (7/16-in.) flakewood board (OSB)	0.0108	44
15.9-mm (5/8-in.) particle board	0.0260	
12.7-mm (1/2-in.) particle board	0.0155	
12.7-mm (1/2-in.) cement board	0.00	54-108
11.0-mm (7/16-in.) plain fibreboard	0.8223	
11.0-mm (7/16-in.) asphalt impregnated fibreboard	0.8285	772-2465
3.00-mm (1/8-in.) hardboard (standard)	0.0274	630
12.7-mm (1/2-in.) foil back gypsum board	0.00	0.00
12.7-mm (1/2-in.) gypsum board	0.0091	1373
Tongue and groove planks		
2.70-mm (3/32-in.) modified bituminous torch on grade membrane (polyester reinforced mat)	0.00	4.0
2.70-mm (3/32-in.) modified bituminous torch on grade membrane (glass fibre mat)	0.00	4.0
1.50-mm (1/16-in.) modified bituminous self-adhesive membrane	0.00	01.9
1.50-mm (1/16-in.) smooth surface roofing membrane	0.00	3.4-3.7
13.6-kg (30-lb) roofing felt	0.1873	160
6.8-kg (15-lb) non-perforated asphalt felt	0.2706	320
6.8-kg (15-lb) perforated asphalt felt	0.3962	800
Plastic and Metal Foils and Films		
0.15-mm (6-mil) polyethylene	0.00	1.6-5.8
0.03-mm (1-mil) aluminum foil	0.00	0.00
Reinforced non-perforated polyolefin	0.0195	
Spunbonded polyolefin film	0.9593	3646
Spunbonded polypropylene film	3.2186	884
0.10-mm (4.00-mil) Type I perforated polyethylene	4.0320	
0.10-mm (4.00-mil) Type II perforated polyethylene	3.2307	
Thermal Insulations		
38.0-mm (1.5-in.) extruded polystyrene	0.00	15-60
25.4-mm (1-in.) foil back urethane insulation	0.00	0.00
25.4-mm (1-in.) phenolic insulation board	0.00	133
50.8-mm (2-in.) phenolic insulation board	0.00	67
25.0-mm (1-in.) expanded polystyrene - Type II	0.1187	86-160
Glass fibre rigid insulation board with spunbonded polyolefin film on one face	0.4880	1143
25-mm (1-in.) expanded polystyrene - Type I	12.2372	115 - 333
152-mm (6-in.) glass fibre wool insulation	36.7327	1110
Vermiculite insulation	70.4926	1666
Cellulose insulation (spray on)	86.9457	1666

AB = Air Barrier
VB = Vapour Barrier

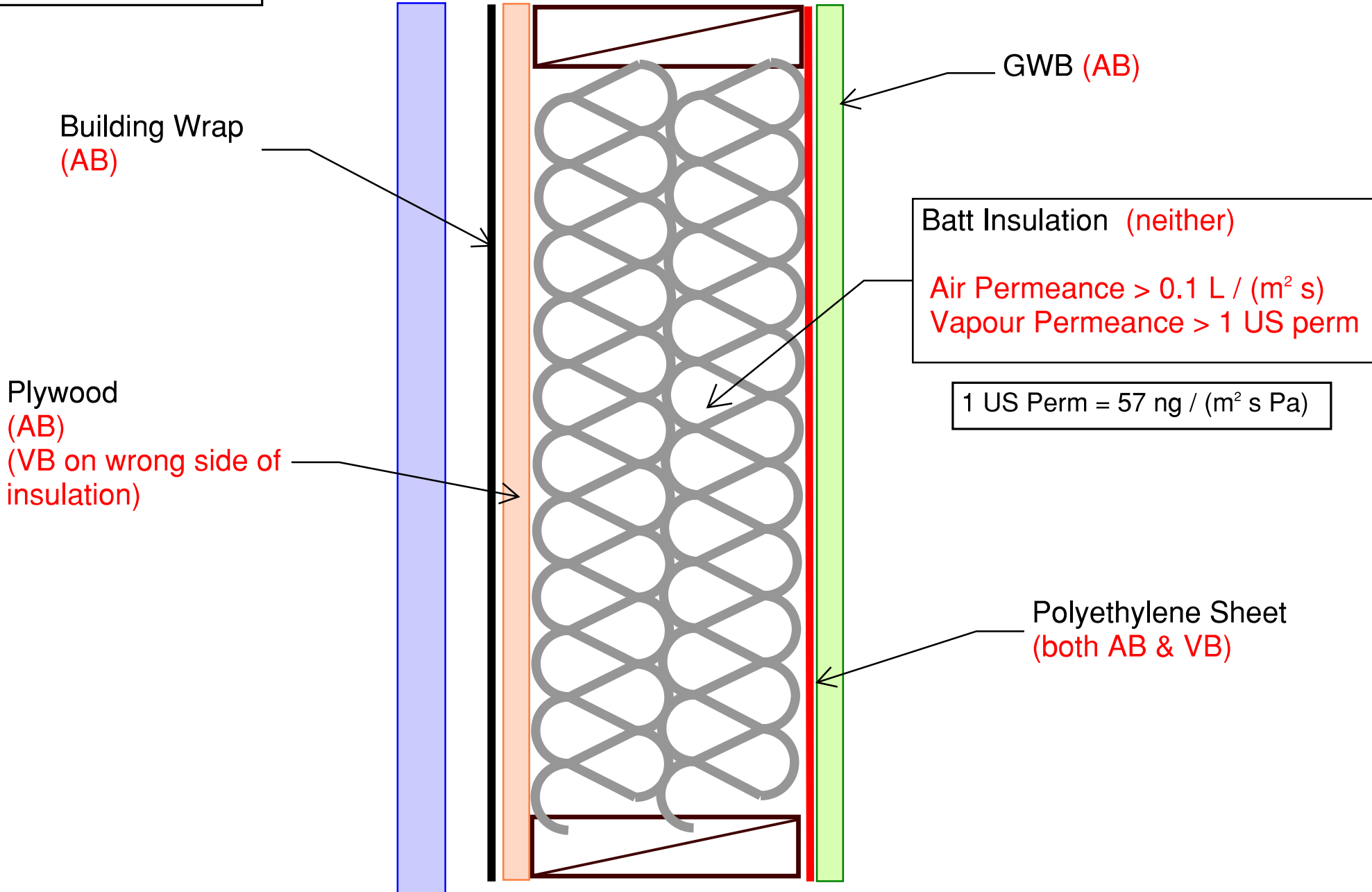

Walls and Roof & Floor

Building Envelope

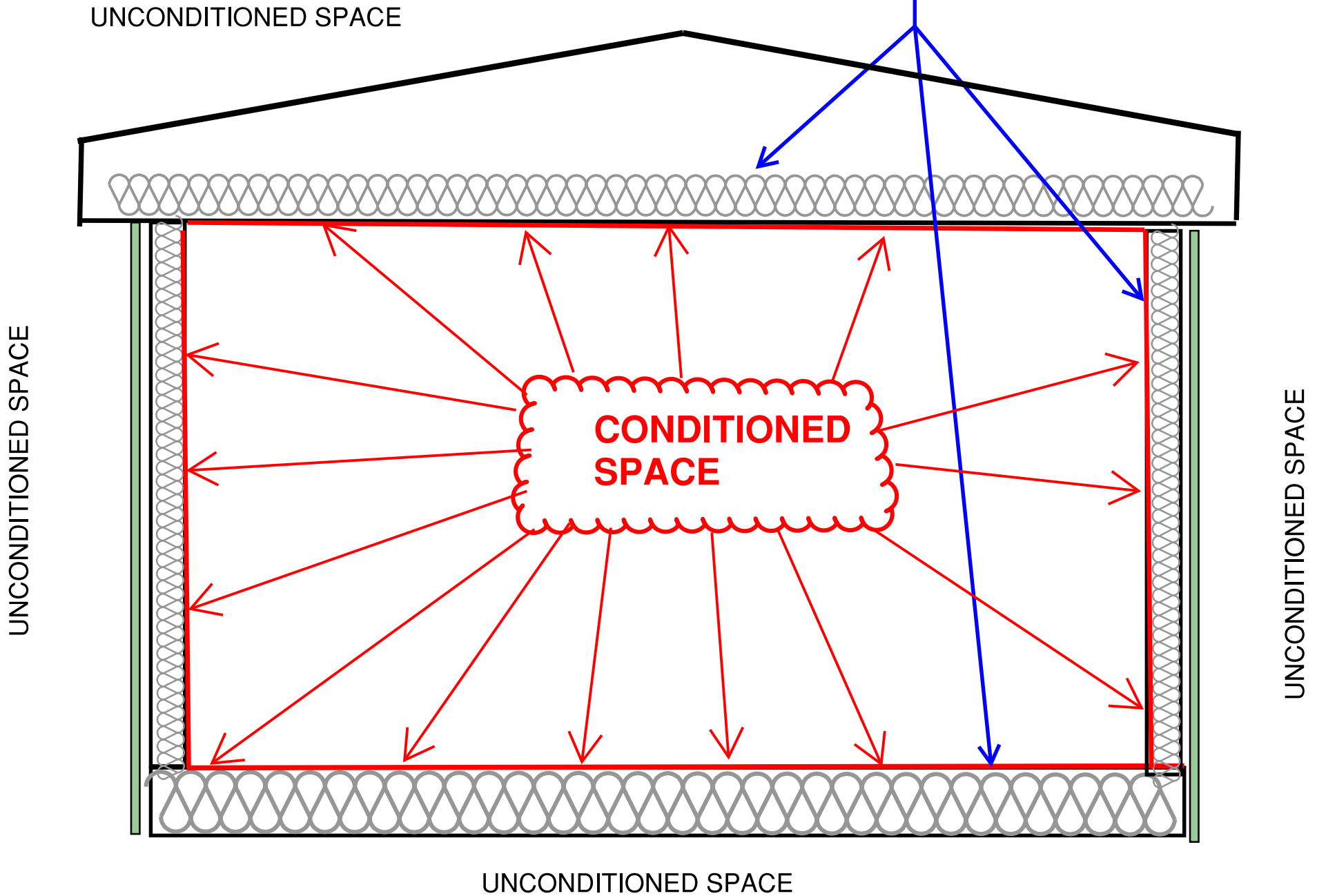

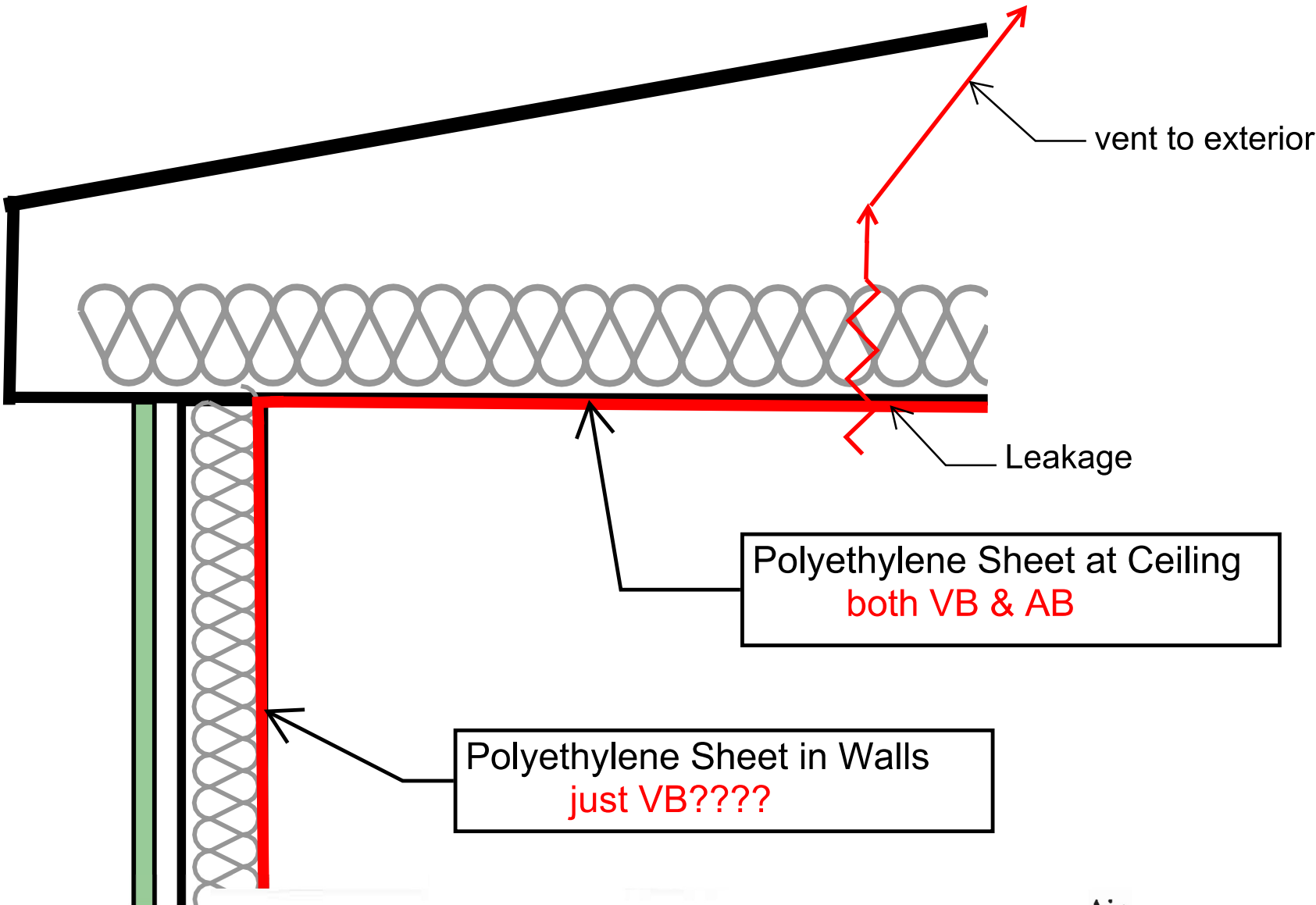

	Air Permeance	Vapour Permeance
	Measured Leakage 75 Pa L/(s•m ²)	ng/(Pa•s•m ²)
Wall VB	0.00	1.6-5.8
Building Wrap	0.02	3200

Traditional Wall Assemblies

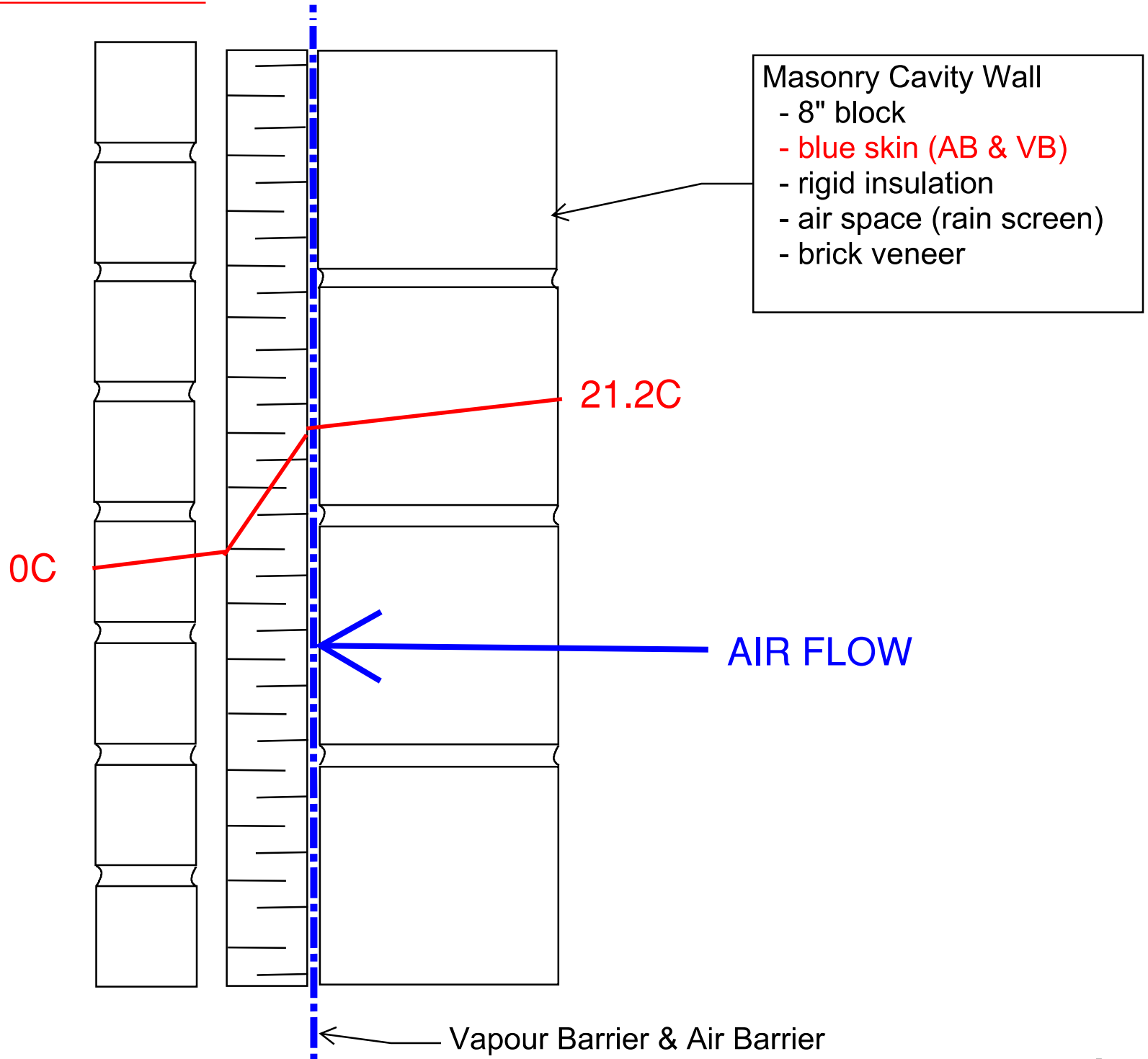

Unconventional Wall Assemblies

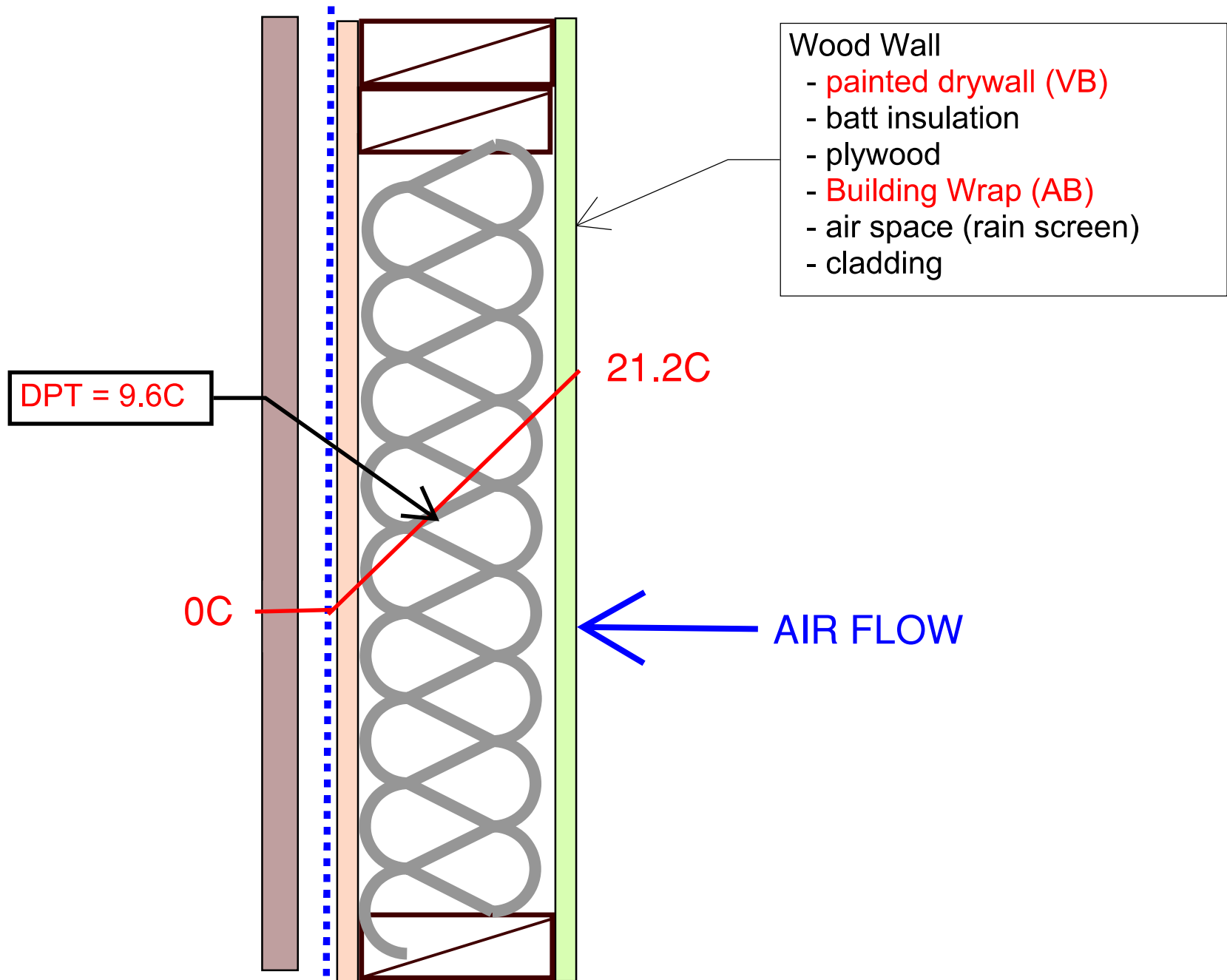

More Confusion

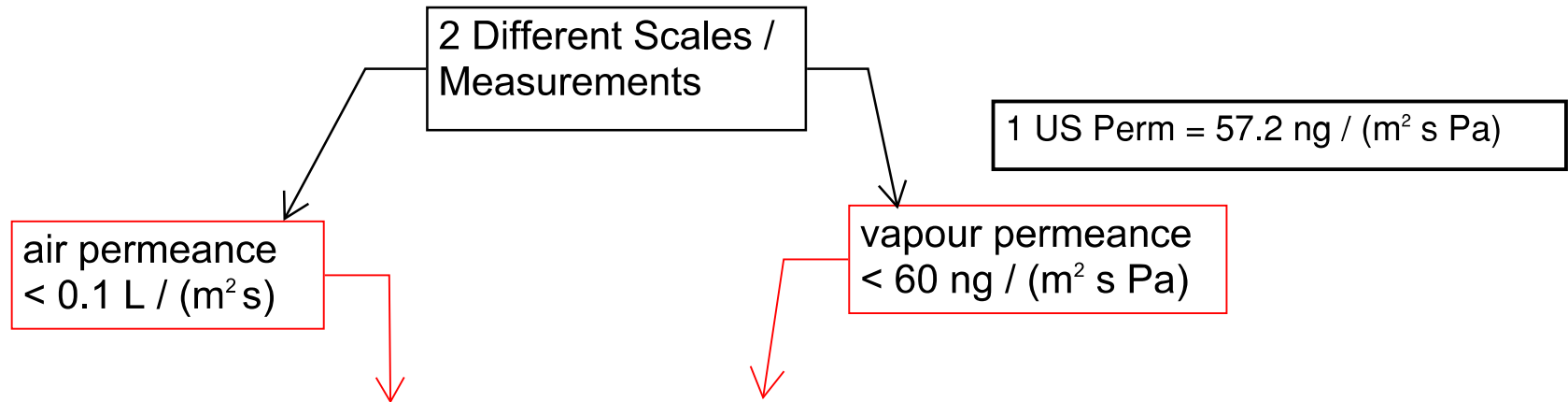

(1) **Impermeable Air Barriers < 1 US Perms**

- polyethylene ("poly")
- Blueskin

(used for both AB & VB on interior assembly)

(2) **Semi-permeable Air Barriers = 1 - 10 US Perms**

(used only as AB on exterior assembly)

(3) **Permeable Air Barriers > 10 US Perms**

(Breathable Air Barriers)

- building wraps (spunbound polyethylene fibers)
- (used only as AB on exterior assembly)

Purpose of Building Wrap

- (1) Weather Barrier
(water barrier)
(moisture barrier)

(2nd plane of protection)

Water beads on surface

- (2) Reduces wind infiltration

- (3) Protects exposed wood sheathing during construction

Driving Rain →

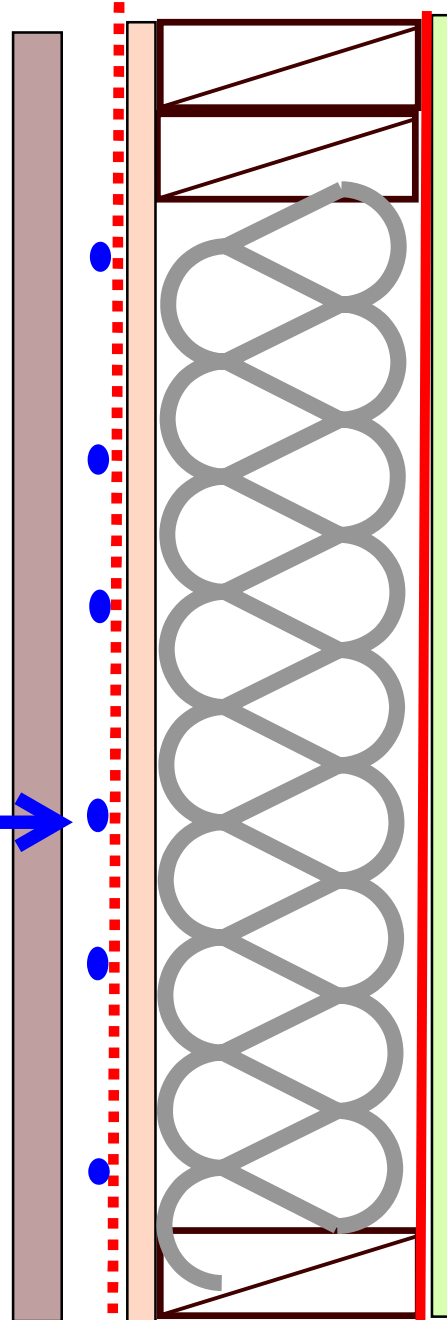

Common Wall Assembly

- drywall
- poly (VB & AB)
- batt insulation
- plywood
- **Building Wrap (weather barrier)**
- air space (rain screen)
- cladding

Some Take Aways

- (1) Vapour barrier is always required and always on warm side of dew point
(and preferable completely on warm side of insulation)
- (2) Any interior air leakage in building envelope should be able
"escape" to exterior
- (3) Exterior air should be able infiltration into assembly
(to dry out any moisture with assembly)
- (4) Holes & gaps is the largest amount of air leakage
Diffusion is only small component of air leakage
- (5) Want as little air leakage as possible (but some air leakage is inevitable)
- (6) Air Barrier could be on either side of insulation
(but preferable on warm side)
- (7) If Air Barrier on cold side then needs to be permeable
(allow air & water migration out)